

PRODUCT CERTIFICATE

PRODUCT APPLICATION

CONLIT insulation solutions for ventilation ducts

MANUFACTURER

Rockwool Finland Oy
Silkkitehtaantie 5 G 3B
01300 Vantaa
Finland

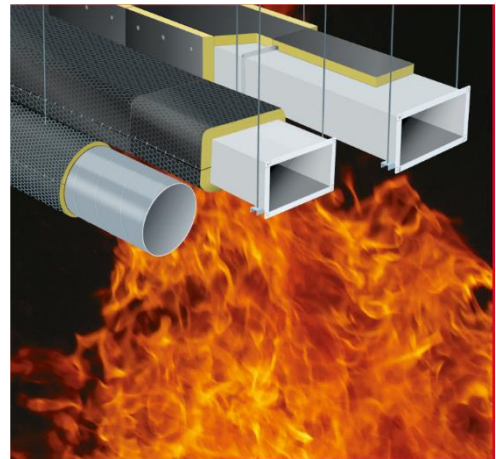

PRODUCT DESCRIPTION

CONLIT fire insulation solutions for ventilation ducts consist of stone wool insulations manufactured by Rockwool Group and specified in this certificate, fastenings and sealants. In this certificate the installation principles and fire resistance capability of the assembled Rockwool fire insulation solutions are presented. Suitable Rockwool fire insulation solution is selected according to the type of the ventilation duct and required fire resistance class.

The insulation materials used in the CONLIT fire insulation solutions are CE-marked according to standard EN 14303. CE-marking according to EN 14303 cannot be used to declare fire resistance.

CERTIFICATION PROCEDURE

This certificate has been issued by Eurofins Expert Services Oy, which is a certification body (S017) accredited by FINAS.

This certificate is based on certification criteria no. SERT R045, type testing of the insulation system and manufacturer's quality assurance according to section 3 of this certificate. The general certification procedures are based on the certification system of Eurofins Expert Services Oy.

The conditions of validity of this certificate are described in section 10.

REGULATIONS, STANDARDS AND INSTRUCTIONS

1 Regulations

According to the assessment of Eurofins Expert Services Oy, CONLIT fire insulation systems, if used in accordance with the provisions of this certificate, will contribute to meet the relevant requirements of the Finnish building legislation as stated in the following:

848/2017 Degree on the fire safety of buildings, in accordance with section 7 of this certificate

2 Other instructions and requirements

Other instructions and requirements applicable to the product:

EN 14303 Thermal insulation for building equipment and industrial installations – Factory made mineral wool (MW) products - Specification

SERT R045 Eurofins Expert Services Oy certification rules based on tests according to EN 1366-1 and partly applying EXAP EN 15882-1:2011

Installation manual ROCKWOOL CONLIT® Fire Protection. Installation guide

PRODUCT INFORMATION

3 Product description, marking and quality control

In the CONLIT fire insulation solutions the following products are used

Stone wool wired mats	Conlit Fire Mat EI30 Conlit Fire Mat EI60 Conlit Fire Mat EI60/90 Conlit Fire Mat EI120
Stone wool slabs	Conlit Fire Board EI30 Conlit Fire Board EI60 Conlit Fire Board EI90 Conlit Fire Board EI120
Sealing products for penetrations	Rockwool stone wool, loose wool, density as specified in the installation instructions Conlit glue
Fastenings	As defined in the installation instructions and Annex A2

The nominal density and thickness of the insulation materials required in each circular and rectangular duct fire resistance class is given in section 7 of this certificate.

Essential characteristics according to standard EN 14303 are declared by the manufacturer in the declarations of performance, available from the manufacturer.

The insulation materials are identified by the marking on the packages, which include product name, manufacturer's name, production time, dimensions, and other product information.

The manufacturer performs factory production control of the insulation materials according to the standard EN 14303.

The procedures to ensure the functionality of the fire insulation solutions are the following:

- The manufacturer ensures that the installation instruction manual and this certificate are made readily available.
- No changes to the fire insulation solutions or products are made before Eurofins Expert Services Oy has evaluated the effect of the changes to the fire resistance given in this certificate.
- Insulation materials used in the fire insulation solutions are clearly and unambiguously marked with product label.
- The manufacturer ensures that the installation companies have been instructed to document the installation using the installation report according to Annex A1.
- The manufacturer ensures that the installation companies have been instructed to deliver a copy of the installation report together with the copy of this certificate for filing in the construction documentation.
- The installed fire insulations are identifiable.

The assessment of conformity of the installed insulations is not covered by this certificate.

4 Delivery and storage on site

The insulation materials are packed into plastic or cardboard and delivered to site in plastic-covered pallets.

The insulation materials are delivered and stored according to the manufacturer's instructions to prevent them from getting wet, dirty or damaged.

DESIGN INFORMATION

5 General

The design information given in this certificate is based on the assumption that the structural solutions, fastening methods and other initial data are accordant to this certificate and the given requirements, instructions and standards are followed.

6 Installation

The products are installed according to the manufacturer's installation guide. Figures concerning the installation principles of insulation materials and penetrations of circular and rectangular ducts are presented in Annex A2. A template of the installation report is presented in Annex A1.

7 Fire safety

The requirements for the fire safety of buildings and building products used in them are given in the National Building Code of Finland 848/2017, Degree on the fire safety of buildings.

The results for fire resistance presented in this certificate are valid provided that the ventilation ducts meet the requirements given in the National Building Code of Finland, the requirements given in this certificate are fulfilled, and the fire insulation of the ducts has been performed according to the manufacturer's installation instructions and as described in Annex A2.

Manufacturer has declared the reaction to fire class A1 according to EN 13501-1 for the insulations.

The fire resistance of insulated circular spiral ducts made of galvanized steel or rectangular ducts made of galvanized steel sheet for internal and external fire exposure (o↔i) in horizontal and vertical orientations (ve ho) is presented in Tables 1 and 2.

Table 1. Insulation thickness and nominal density in different fire resistance classes of circular ducts insulated with CONLIT Fire Mat EI30, CONLIT Fire Mat EI60/90 or CONLIT Fire Mat EI120

Insulation	Class	Insulation thickness	Nominal density	Facing
Conlit Fire Mat EI30	EI 30 (ve ho o↔i)	50 mm	70 kg/m ³	Black aluminium foil
Conlit Fire Mat EI60	EI 60 (ve ho i ↔ o) S	70 mm	80 kg/m ³	Black aluminium foil
Conlit Fire Mat EI60/90	EI 60 (ve ho o↔i)	80 mm	80 kg/m ³	Black polyester fleece
Conlit Fire Mat EI60/90	EI 90 (ve ho o↔i)	80 mm	80 kg/m ³	Black polyester fleece
Conlit Fire Mat EI120	EI 120 (ve ho o↔i)	100 mm	80 kg/m ³	Black polyester fleece

Table 2. Insulation thickness and nominal density in different fire resistance classes of rectangular ducts insulated with CONLIT Fire Mat EI30, CONLIT Fire Board EI30, CONLIT Fire Board EI60, CONLIT Fire Board EI90 or CONLIT Fire Board EI120

Product	Class	Insulation thickness	Nominal density	Facing
Conlit Fire Mat EI30	EI 30 (ve ho o↔i)	60 mm	70 kg/m ³	Black aluminium foil
Conlit Fire Board EI30	EI 30 (ve ho o↔i)	60 mm	100 kg/m ³	Black aluminium foil
Conlit Fire Board EI60	EI 60 (ve ho o↔i)	60 mm	160 kg/m ³	White or black aluminium foil
Conlit Fire Board EI90	EI 90 (ve ho o↔i)	80 mm	180 kg/m ³	Black aluminium foil
Conlit Fire Board EI120	EI 120 (ve ho o↔i)	90 mm	180 kg/m ³	Black aluminium foil

Diameter of the circular steel ducts shall be ≤ 1000 mm. The width of the cross section of the rectangular duct shall be ≤ 1250 mm and height ≤ 1000 mm. Leakage class of the duct shall be as given in Table 3 or better. The thickness of the duct steel sheet in relation to the cross section dimensions of the duct shall fulfil the requirements given in Table 4 and in addition, strength as of the tested system or better.

The insulation thickness in each fire resistance class in Tables 1 and 2 may be increased by maximum 20 %. Load capacity of vertically oriented duct supports shall ensured.

Table 3. Leakage class requirement of the duct for different CONLIT insulations

Duct type	Insulation	Leakage class, min.
Circular	Conlit Fire Mat EI30	B
	Conlit Fire Mat EI60	D
	Conlit Fire Mat EI60/90	B
	Conlit Fire Mat EI120	D
Rectangular	Conlit Fire Mat EI30	C
	Conlit Fire Board EI30	B
	Conlit Fire Board EI60	
	Conlit Fire Board EI90	
	Conlit Fire Board EI120	

Table 4. Minimum steel thickness of the ventilation duct to be insulated

Duct type	Cross section dimensions of the duct	Steel thickness
Circular	Ø 63 - 315 mm	min. 0,5 mm
	Ø 400 - 1000 mm	min. 0,7 mm
Rectangular	longer side ≤ 300 mm	min. 0,5 mm
	longer side > 300 - 800 mm	min. 0,7 mm
	longer side > 800 - 1250 mm	min. 0,9 mm

Fire resistance of the separating structure shall be equal to or higher than the fire resistance of the insulated duct. Depending on the insulation solution, the following requirements for the separating structures shall be fulfilled the requirements given in Table 5.

Table 5. Requirements for separating structures

Insulation	Separating wall	Separating slab	Fire resistance of the separating structure
Circular ducts			
Conlit Fire Mat EI30	Flexible or rigid, thickness ≥70 mm	Rigid, thickness ≥100 mm	≥ EI 30
Conlit Fire Mat EI60	Rigid, thickness ≥95 mm	Rigid, thickness ≥100 mm	≥ EI 60
Conlit Fire Mat EI60/90	Rigid, thickness ≥100 mm	Rigid, thickness ≥150 mm	≥ EI 60
Conlit Fire Mat EI120	Rigid, thickness ≥150 mm	Rigid, thickness ≥150 mm	≥ EI 120
Rectangular ducts			
Conlit Fire Mat EI30	Flexible or rigid, thickness ≥70 mm	Rigid, thickness ≥150 mm	≥ EI 30
Conlit Fire Board EI30	Flexible or rigid, thickness ≥70 mm	Rigid, thickness ≥100 mm	≥ EI 30
Conlit Fire Board EI60	Flexible or rigid, thickness ≥95 mm	Rigid, thickness ≥100 mm	≥ EI 60
Conlit Fire Board EI90	Flexible or rigid, thickness ≥130 mm	Rigid, thickness ≥150 mm	≥ EI 90
ConliT Fire Board EI120	Flexible or rigid, thickness ≥130 mm	Rigid, thickness ≥ 150 mm	≥ EI 120

Density of the rigid constructions shall be at least 450 kg/m³.

Penetration of the duct shall be sealed according to Figures 1 - 8 (circular ducts) or Figures 10 - 19 (rectangular ducts) in Annex A2.

Vertically oriented ducts shall be supported so that the requirements for the supporting components given in Table 6 are fulfilled.

Table 6. Requirements for vertically oriented duct support components

Insulation	Maximum tensile stress in all vertically orientated components	Shearing stress in screws ¹⁾
≤ EI 60	9 N/mm ²	≤ 15 N/mm ²
> EI 60 - ≤ EI 120	6 N/mm ²	≤ 10 N/mm ²

¹⁾ Screws of property class 4.6 according to EN 20898-1

Maximum distance between suspension devices, maximum distance of a suspension devices from the joint of the duct, from the joint of insulation and from the separating construction are given in Figure 9 (circular ducts) and Figure 20 (rectangular ducts) in Annex A2.

The lateral distance between the outer vertical surface of the steel duct and the centreline of the suspension rod shall not exceed 50 mm, except with CONLIT Fire Board EI90 insulation the distance shall not exceed 10 mm.

Vertical ducts shall be connected to supporting constructions at every floor however, distance between supporting constructions shall not exceed 5 m.

If the ratio between the length of the duct exposed in the compartment to the outer diameter across the outside face of the duct exceeds 8:1, additional lateral supports are needed so that this ratio is not exceeded.

Access panels are not included in the certified solutions.

One, two or three sided ventilation ducts

When one, two or three sided ventilation ducts are in question, the suspension of ducts is different from the requirements of the test standard. In that case the fire insulation of a ventilation duct can be performed using an insulation that has been tested for the required fire resistance class and installing it according to the alternative installation methods recommended by the manufacturer. In these cases it is recommended to select a solution fulfilling higher fire resistance class than the fire resistance class required for the building site.

Insulation of opening larger than tested. Applicable in resistance to fire class EI 30

In resistance to fire class EI 30 the opening between duct and separating structure, having maximum dimensions as given in Table 7, can be sealed using two Conlit Coated Batt 50 mm boards, density 160 kg/m³, or Conlit Coated Batt 60 mm board, density 180 kg/m³. As duct insulation Conlit Fire Board EI30 is used in rectangular ducts and Conlit Fire Mat EI30 in circular ducts.

Table 7. Maximum distance between ventilation duct and separating structure. Resistance to fire class EI 30. Opening sealed with Conlit Coated Batt insulation board.

Height and width of the opening	≤ 1000 mm	> 1000 mm	≤ 1000 mm	> 1000 mm
Insulation used in the opening	2 x Conlit Coated Batt 50 mm		1 x Conlit Coated Batt 60 mm	
Circular horizontal duct				
Maximum distance between duct and separating structure	300 mm	200 mm	150 mm	100 mm
Circular vertical duct				
Maximum distance between duct and separating structure	300 mm	300 mm	150 mm	150 mm
Horizontal rectangular duct				
Maximum distance between duct and separating structure				
- on the sides and below the duct	300 mm	200 mm	150 mm	100 mm
- above the duct	600 mm	200 mm	150 mm	100 mm
Vertical rectangular duct				
Maximum distance between duct and separating structure	300 mm	300 mm	150 mm	150 mm

In flexible walls and before installing Conlit Coated Batt insulation, gypsum boards shall be installed on all four sides of the opening. With gypsum boards at least the same resistance to fire class with the separating wall shall be reached.

All cut edges of Conlit Coated Batt insulation boards shall be sealed, over the entire thickness of the board, with Conlit Seal 800 or Conlit Seal.

To seal the opening two Conlit Coated Batt 50 mm boards on top of each other with staggering seams, or one Conlit Coated Batt 60 mm board is tightly fitted into the opening and the joint is sealed with Conlit Seal 800 or Conlit Seal.

Horizontal duct is supported on both sides of the penetration from the bottom and top of the duct with L-profile with minimum dimensions of 50 x 50 x 5 mm. The profiles are attached to the separating structure with four screws per profile (Appendix A2, Figure 21). In flexible wall, the first screw must be attached to the steel profile of the wall, and screws and steel anchors must be used for fastening. The duct is attached to the profile with 25 x 4,2 mm self-tapping screws.

Vertical duct is supported on the upper side of the penetration with L-profile with minimum dimensions of 50 x 50 x 5 mm, which in rectangular ducts are installed on the long sides of the duct and in round ducts parallel to opposite sides of the duct. The profiles are attached to the separating structure with four screws per profile (Appendix A2, Figure 21). The duct is attached to the profile with 25 x 4,2 mm self-tapping screws.

Conlit Seal 800 or Conlit Seal and Conlit glue shall be used in joints and cut edges as given in Annex A2 Figures 22 and 23. For other parts the penetrations are sealed as shown in Annex A2 Figures 1, 2, 12 and 13.

INSTRUCTIONS FOR INSTALLATION AND USE

8 Manufacturer's instructions

Installation of the fire insulation solution shall be made according to the manufacturer's instructions. Installation company prepares an installation report according to the Annex A1.

Material safety data sheets, declarations of performance and installation instructions are available from the manufacturer.

VALIDITY OF THE CERTIFICATE

9 Validity period of the certificate

This certificate is valid until June 29, 2028.

The validity of the certificate may be confirmed at Eurofins Expert Services Oy web pages.

10 Conditions of validity

The certificate is valid assuming that no fundamental changes are made to the product, and that the manufacturer has a valid contract on certification.

11 Other conditions

The references made in this certificate to standards and instructions are valid in the format used at the time the certificate was signed.

The recommendations in this certificate concerning the safe use of this product are minimum requirements that shall be satisfied when using the product. The certificate does not override current or future requirements imposed by laws and statutes. In addition to the issues presented in this certificate, design, manufacturing and use shall follow appropriate construction methods.

The manufacturer is in charge of the product's quality and factory production control. In awarding this certificate, Eurofins Expert Services Oy does not bind itself to indemnification liability concerning personal injury or other damage that may directly or indirectly result from using the product described in this certificate.

This updated certificate C-12188-17 (issued first on December 7, 2017) has been granted as described above to Rockwool Finland Oy.

On behalf of Eurofins Expert Services Oy on January 21, 2025

Katja Vahtikari
Manager, Construction certification

Tatu Toivonen
Senior Expert

This document has been signed electronically

ANNEX A1: Installation report

CERTIFICATE NO. C-12188-17

Products installed:	Circular duct	Rectangular duct	Fire resistance class	Insulation thickness
Conlit Fire Mat EI30 <input type="checkbox"/>	<input type="checkbox"/>	<input type="checkbox"/>	EI ____	
Conlit Fire Mat EI60/90 <input type="checkbox"/>	<input type="checkbox"/>	<input type="checkbox"/>	EI ____	
Conlit Fire Mat EI60 <input type="checkbox"/>	<input type="checkbox"/>	<input type="checkbox"/>	EI ____	
Conlit Fire Mat EI120 <input type="checkbox"/>	<input type="checkbox"/>	<input type="checkbox"/>	EI ____	
Conlit Fire Board EI30 <input type="checkbox"/>	<input type="checkbox"/>	<input type="checkbox"/>	EI ____	
Conlit Fire Board EI60 <input type="checkbox"/>	<input type="checkbox"/>	<input type="checkbox"/>	EI ____	
Conlit Fire Board EI90 <input type="checkbox"/>	<input type="checkbox"/>	<input type="checkbox"/>	EI ____	
Conlit Fire Board EI120 <input type="checkbox"/>	<input type="checkbox"/>	<input type="checkbox"/>	EI ____	
Sealing products:				

Installation site:

Site identification	
Address	
Installation site specifications (building part, floor, rooms)	
Installation time	
Additional information	

Installation company:

Name	
Address	
Name of the installer	
Contact information (phone and e-mail)	

Products have been installed according to the manufacturer's installation instructions

Place and date: _____, _____.20____

Signature: _____

Clarification of signature: _____

ANNEXA2: Fire insulation details

Figure 1: Circular horizontal duct, insulation CONLIT Fire Mat EI30, fire resistance class EI 30

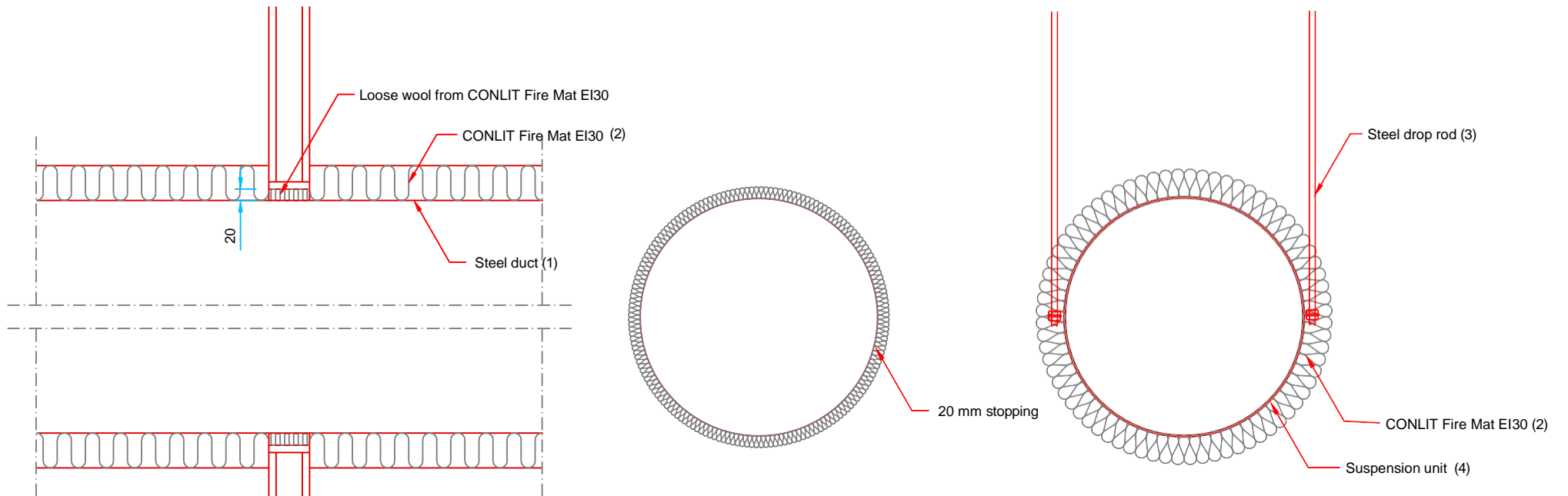

1	Steel duct Lindab SR with Lindab nipples NPU fixed with 3.2 x 16 mm screws c/c 250 mm and sealed with EPDM rubber at the each end of the nipple or similar
2	CONLIT Fire Mat EI30: thickness 50 mm, density 70 kg/m ³ . Faced with steel mesh sewn to the wool with stainless steel wires, between wool and mesh a black aluminum foil is placed
3	Steel rod dimension, see requirements in table 6
4	Suspension unit Lindab UVH 303 or similar.

Figure 2: Circular vertical duct, insulation CONLIT Fire Mat EI30, fire resistance class EI 30

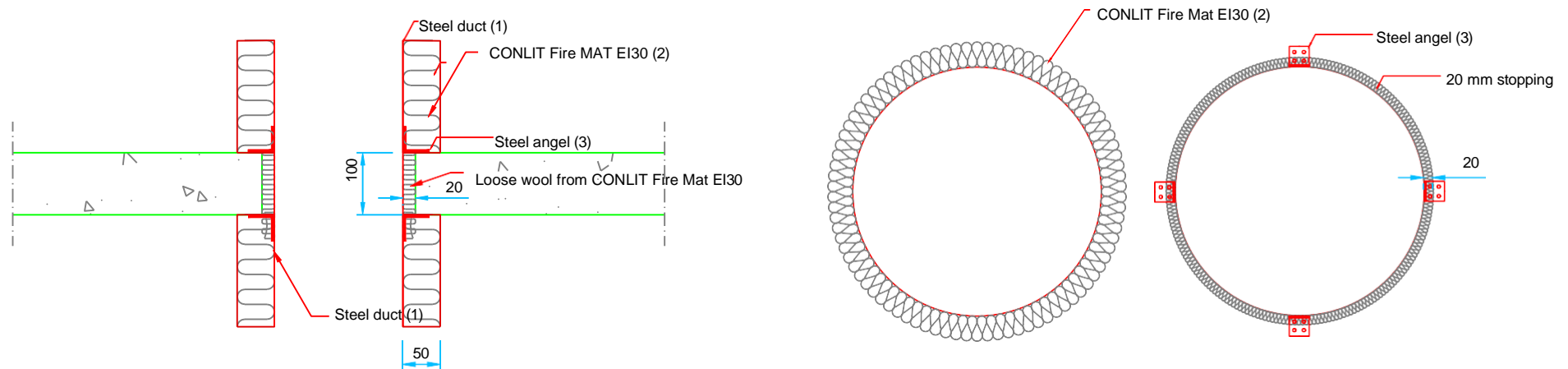

1	Steel duct Lindab SR with Lindab nipples NPU fixed with 3.2 x 16 mm screws c/c 250 mm and sealed with EPDM rubber at the each end of the nipple or similar
2	CONLIT Fire Mat EI30 tickness 50 mm, density 70 kg/m ³ . Faced with steel mesh sewn to the wool with stainless steel wires, between wool and mesh a black aluminum foil is placed
3	Steel angle 40 x 40 x 40 x 3 mm fixed to the duct with 2 pcs 3.2 x 20 mm screws

Figure 3: Circular horizontal duct, insulation CONLIT Fire Mat EI60 and CONLIT Fire Mat EI60/90, fire resistance class EI 60

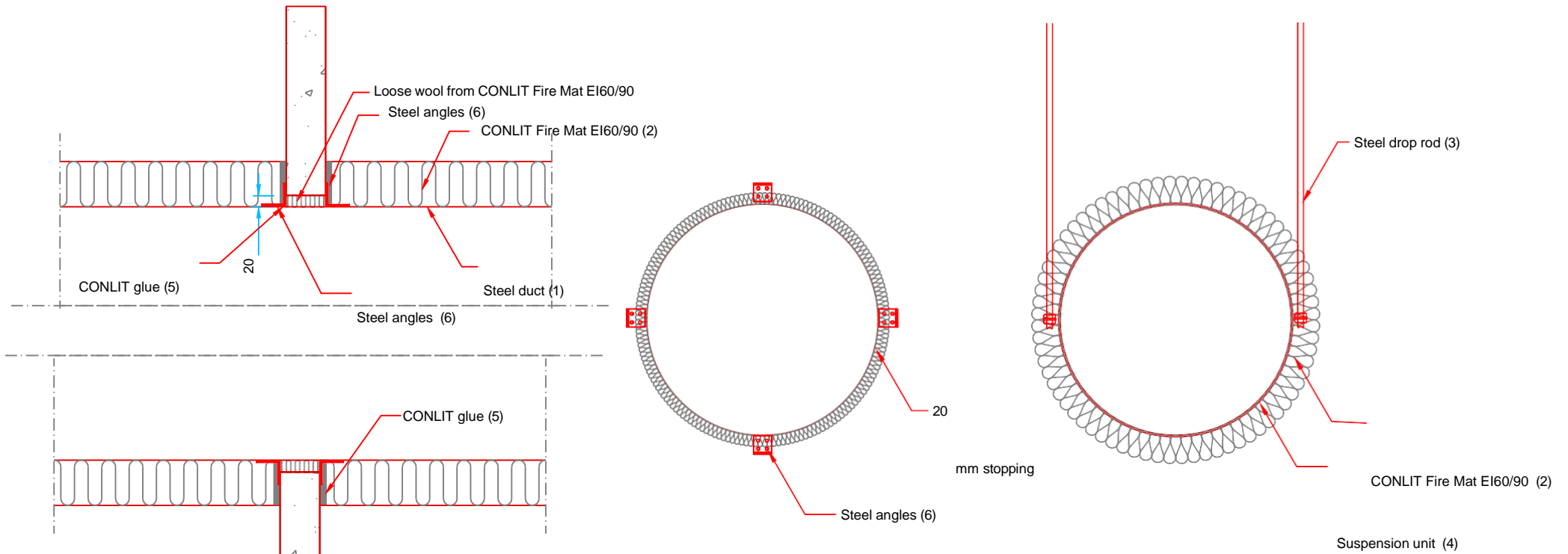

	CONLIT Fire Mat EI60	CONLIT Fire Mat EI60/90
1	Steel duct Lindab SR with Lindab nipples NPU fixed with 3.2 x 16 mm screws c/c 250 mm and sealed with EPDM rubber at the each end of the nipple or similar	Steel duct Lindab SR with Lindab nipples NPU fixed with 3.2 x 16 mm screws c/c 250 mm and sealed with EPDM rubber at the each end of the nipple or similar
2	CONLIT Fire Mat EI60: thickness 70 mm, density 80 kg/m ³ . Faced with steel mesh sewn to the wool with stainless steel wires, between wool and mesh a black aluminum foil is placed	CONLIT Fire Mat EI60/90: thickness 80 mm, density 80 kg/m ³ . Faced with steel mesh sewn to the wool with stainless steel wires, between wool and mesh a black polyester fleece
3	Steel rod dimensions, see requirements in table 6	Steel rod dimensions, see requirements in table 6
4	Suspension unit Lindab UVH 303 or similar	Suspension unit Lindab UVH 303 or similar
5	CONLIT glue	CONLIT glue
6	Steel angle 50 x 50 x 50 x 2.5 fixed to the duct with 4 angles (2 on each side). Self tapping screws 4.2 x 13 mm, 2 pcs. in duct	Steel angles 40 x 40 x 40 x 3 fixed to the duct with 4 angles (4 on each side). 3.2 x 20 mm screws

Figure 4. Circular vertical duct, insulation CONLIT Fire Mat EI60 and CONLIT Fire Mat EI60/90, fire resistance class EI 60

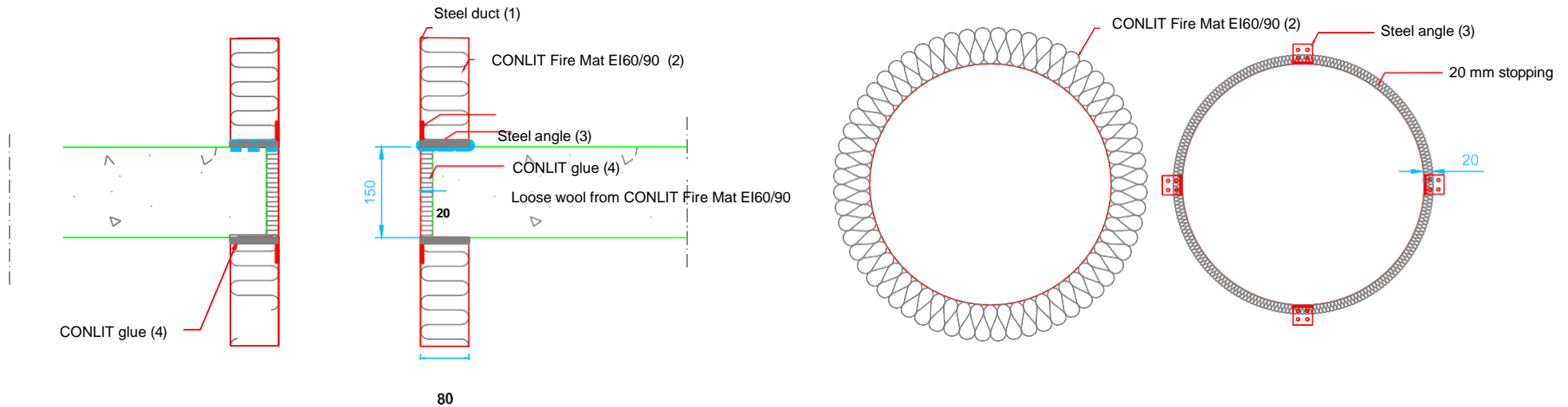

	CONLIT Fire Mat EI60	CONLIT Fire Mat EI60/90
1	Steel duct Lindab SR with Lindab nipples NPU fixed with 3.2 x 16 mm screws c/c 200 mm and sealed with EPDM rubber at the each end of the nipple or similar	Steel duct Lindab SR with Lindab nipples NPU fixed with 3.2 x 16 mm screws c/c 200 mm and sealed with EPDM rubber at the each end of the nipple or similar
2	CONLIT Fire Mat EI60: thickness 70 mm, density 80 kg/m ³ . Faced with steel mesh sewn to the wool with stainless steel wires, between wool and mesh a black aluminum foil is placed.	CONLIT Fire Mat EI60/90: thickness 80 mm, density 80 kg/m ³ . Faced with steel mesh sewn to the wool with stainless steel wires, between wool and mesh a black polyester fleece is placed.
3	Steel angle 50 x 50 x 50 x 2.5 fixed to the duct with 4 angles (2 on each side). Self tapping screws 4.2 x 13 mm, 2 pcs. in duct	Steel angles 40 x 40 x 40 x 3 fixed to the duct with 4 angles (4 on each side). 3.2 x 20 mm screws
4	CONLIT glue	CONLIT glue

Figure 5: Circular horizontal duct, insulation CONLIT Fire Mat EI60/90, fire resistance class EI 90

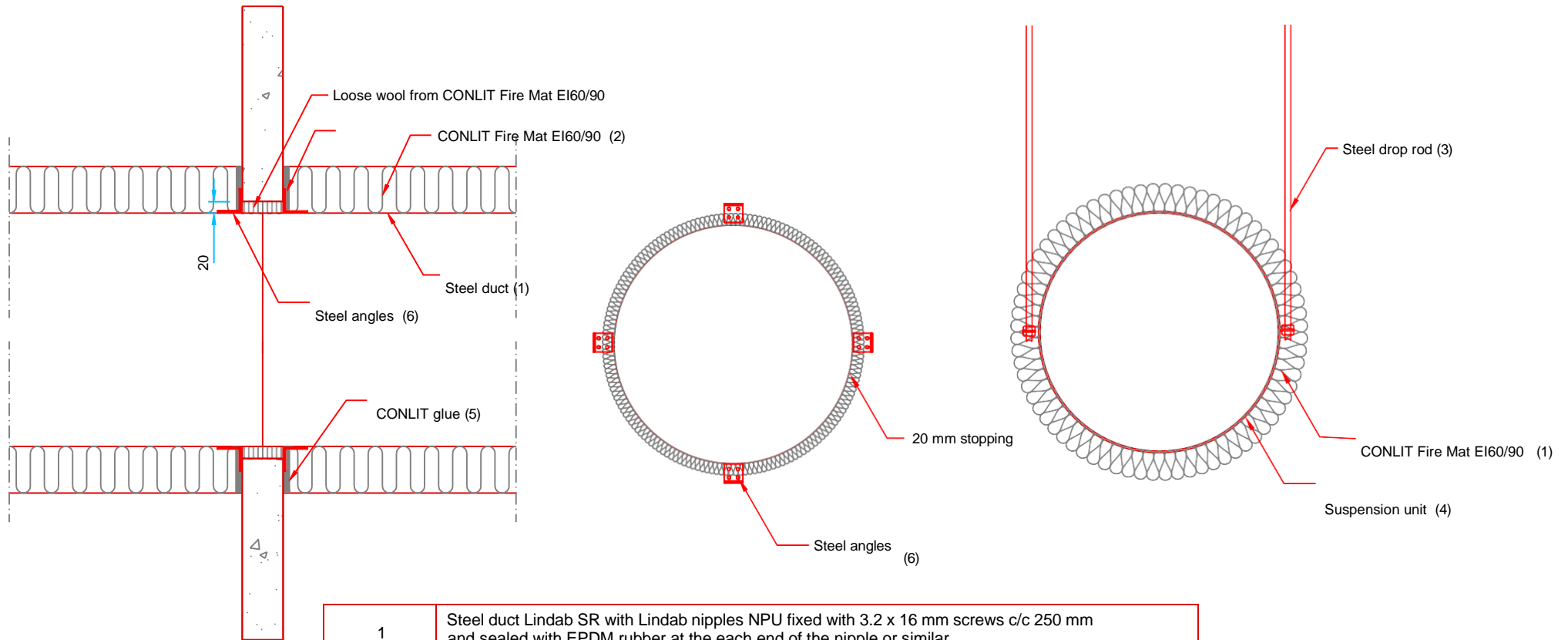

1	Steel duct Lindab SR with Lindab nipples NPU fixed with 3.2 x 16 mm screws c/c 250 mm and sealed with EPDM rubber at the each end of the nipple or similar
2	CONLIT Fire Mat EI60/90: thickness 80 mm, density 80 kg/m ³ . Faced with steel mesh sewn to the wool with stainless steel wires, between wool and mesh a black polyester fleece
3	Steel rod dimensions, see requirements in table 6
4	Suspension unit Lindab UVH 303 or similar
5	CONLIT glue

6

Steel angles 40 x 40 x 30 x 3 fixed to the duct with 2 pcs. 3.2 x 20 mm screws

Figure 6. Circular vertical duct, insulation CONLIT Fire Mat EI60/90, fire resistance class EI 90

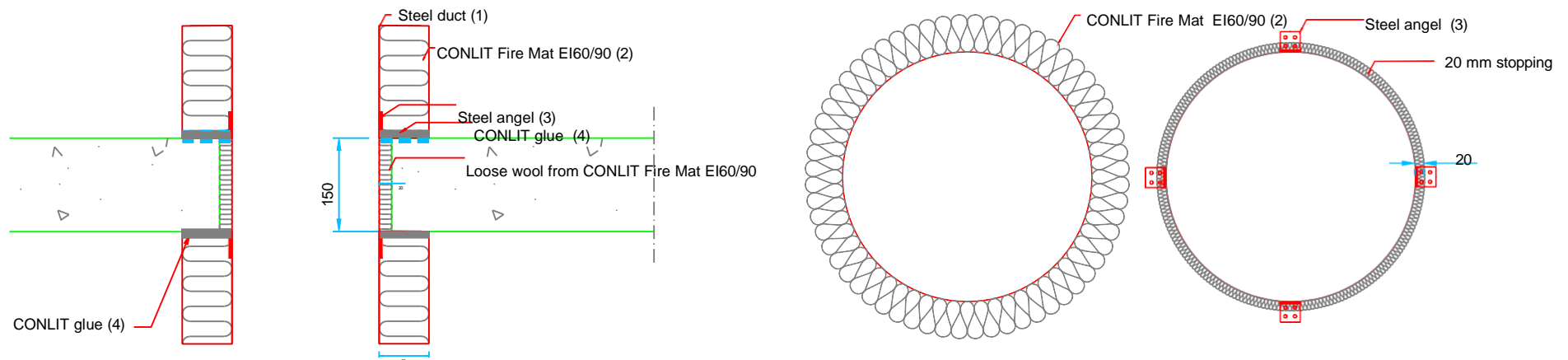

1	Steel duct Lindab SR with Lindab nipples NPU fixed with 3.2 x 16 mm screws c/c 200 mm and sealed with EPDM rubber at the each end of the nipple or similar
2	CONLIT Fire Mat EI60/90: thickness 80 mm, density 80 kg/m ³ . Faced with steel mesh sewn to the wool with stainless steel wires, between wool and mesh a black polyester fleece is placed
3	Steel angle 40 x 40 x 40 x 3 mm fixed to the duct with 2 pcs 3.2 x 20 mm screws
4	CONLIT glue

Figure 7: Circular horizontal duct, insulation CONLIT Fire Mat EI120, fire resistance class EI 120

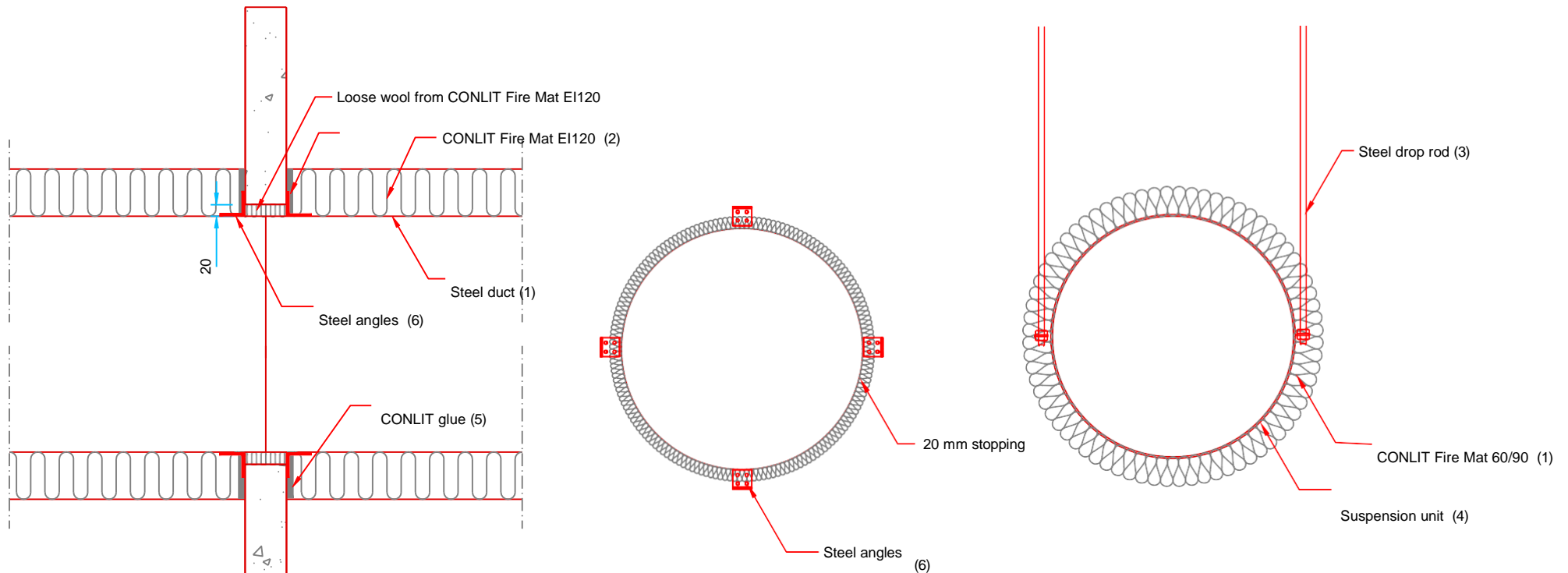

1	Steel duct Lindab SR with Lindab nipples NPU fixed with 3.2 x 16 mm screws c/c 250 mm and sealed with EPDM rubber at the each end of the nipple or similar.
2	CONLIT Fire Mat EI120: thickness 100 mm, density 80 kg/m ³ . Faced with steel mesh sewn to the wool with stainless steel wires, between wool and mesh a black polyester fleece.
3	Steel rod dimensions, see requirements in table 6
4	Suspension unit Lindab UVH 303 or similar.
5	CONLIT glue

6	Steel angles 60 x 60 x 40 x 2 fixed to the duct with 2 pcs. 3.2 x 25 mm screws
---	--

Figure 8. Circular vertical duct, insulation CONLIT Fire Mat EI120, fire resistance class EI 120

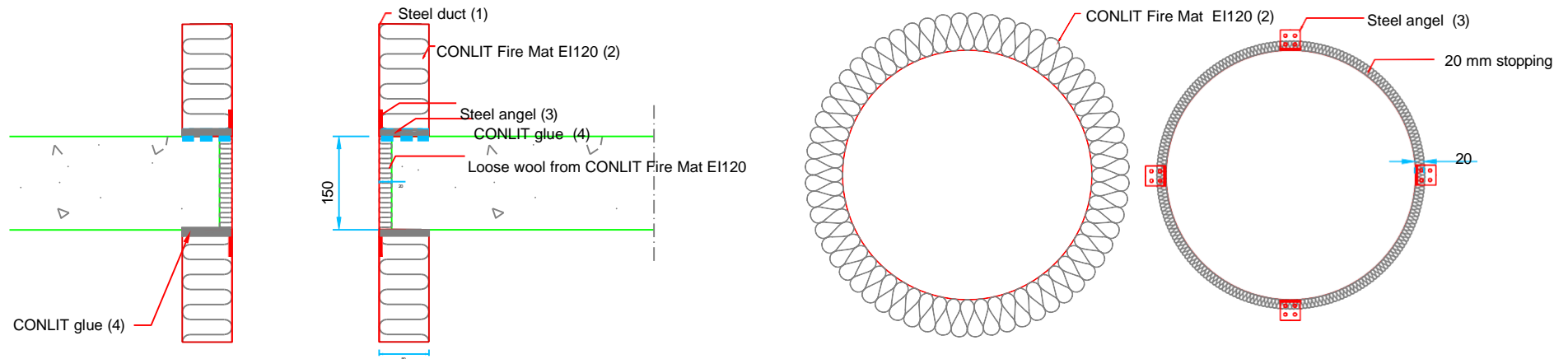

1	Steel duct Lindab SR with Lindab nipples NPU fixed with 3.2 x 16 mm screws c/c 200 mm and sealed with EPDM rubber at the each end of the nipple or similar
2	CONLIT Fire Mat EI120: thickness 100 mm, density 80 kg/m ³ . Faced with steel mesh sewn to the wool with stainless steel wires, between wool and mesh a black polyester fleece is placed
3	Steel angle 50 x 50 x 35 x 2 mm fixed to the duct with 2 pcs 3.2 x 20 mm screws
4	CONLIT glue

Figure 9. Circular ducts: maximum distance between suspension devices and maximum distance of suspension devices from the duct joint, insulation joint and the separating construction

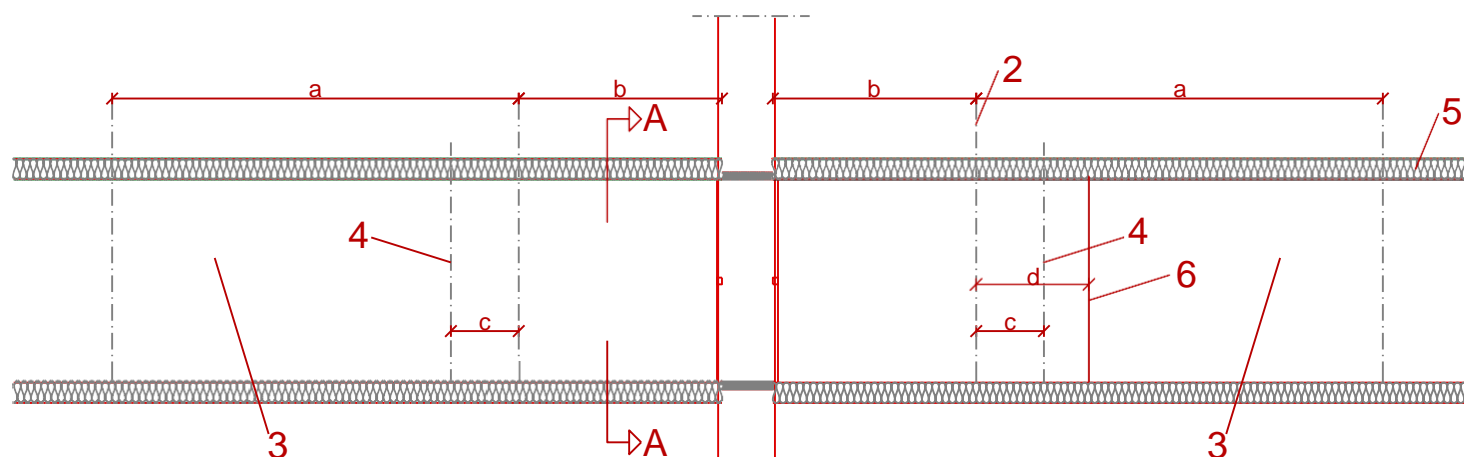

	CONLIT Fire Mat EI30	CONLIT Fire Mat EI 60	CONLIT Fire Mat EI 60/90	CONLIT Fire Mat EI 60/90	CONLIT Fire Mat 120
Fire resistance class	EI 30	EI 60	EI 60	EI 90	EI 120
a Max distance between suspension hangers	1500 mm	1500 mm	1500 mm	1500 mm	1330 mm
b Max distance from wall to hanger	800 + 100 mm	1500 mm	600 + 100 mm	600 + 100 mm	600 + 100 mm
c Max distance from hanger to joint in duct	200 + 100 mm	390 ± 100 mm	200 + 100 mm	200 + 100 mm	155 + 100 mm
d Max distance from hanger to joint in insulation	10 + 100 mm	300 ± 100 mm	10 + 100 mm	10 + 100 mm	210 + 100 mm

1	Penetration	See A-A
2	Drop rod	Steel rod dimensions, see requirements in table 6
3	Duct	Lindab SR
4	Joint in duct	
5	Fire protection	CONLIT Fire Mat
6	Joint in insulation	

Figure 10. Rectangular horizontal duct, CONLIT Fire Mat EI30, fire resistance class EI 30

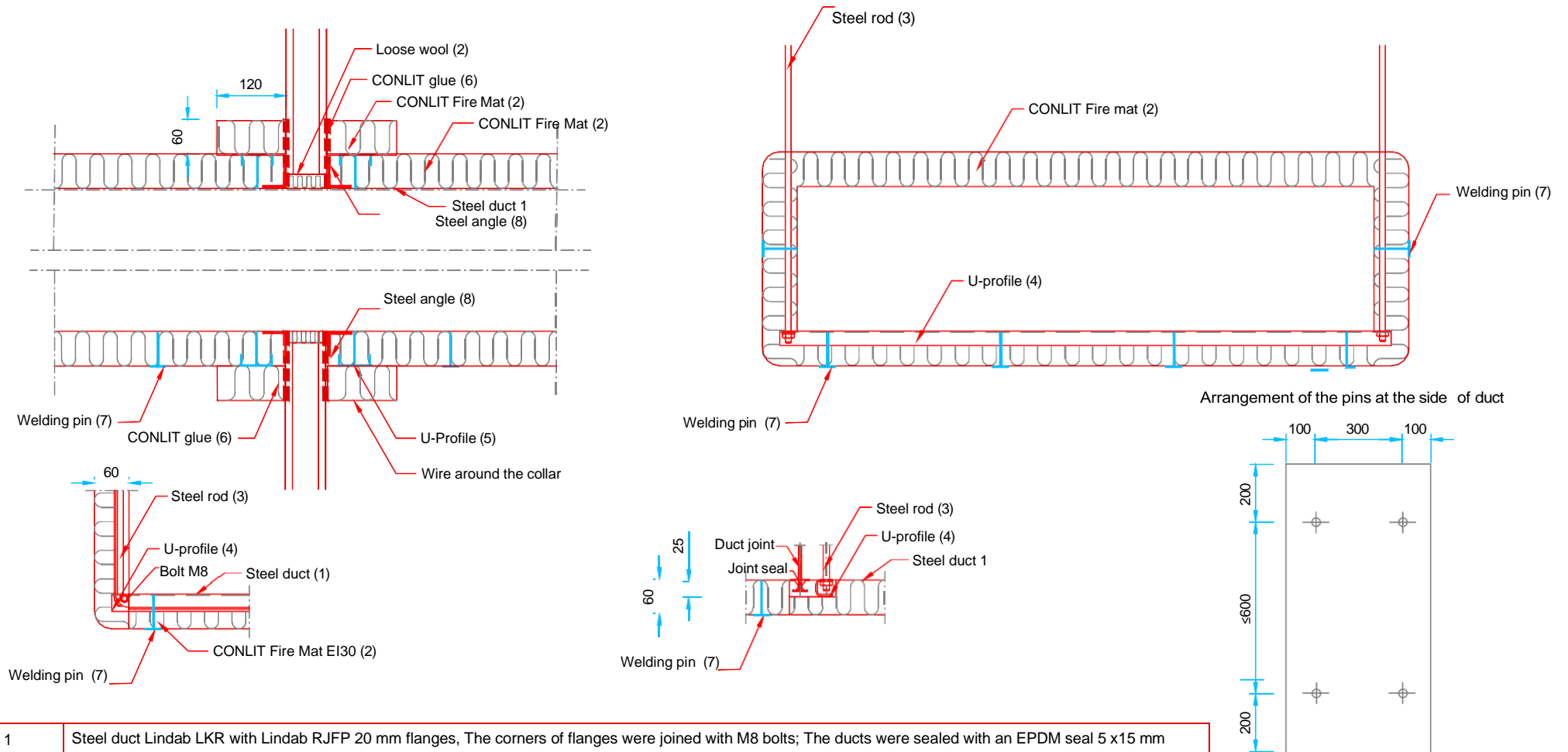

1	Steel duct Lindab LKR with Lindab RJFP 20 mm flanges, The corners of flanges were joined with M8 bolts; The ducts were sealed with an EPDM seal 5 x15 mm
2	CONLIT Fire Mat EI30: thickness 60 mm, density 70 kg/m ³ . Faced with steel mesh sewn to the wool with stainless steel wires, between wool and mesh a black aluminum foil is placed. End of collar surface is covered with the black Alu-foil
3	Steel rod dimensions, see requirements in table 6
4	U-profile Hilti MM-C-30; 30 x 30 x 30x 1 mm or similar
5	U-profile 60 x 25 x 25 x 2,5 mm; approx. 20 mm from the wall at each side fixed to the duct with 100 mm self tapping screws, max c/c 300, at least two screws/profile
6	CONLIT glue
7	Welding pins Ø3 mm with preset washers, length 60 mm Ø30 mm

8	steel angles 40 x 40 x 3 mm 4 pcs. at both sides of the wall fixed to the duct with two 3.2 x 25 mm screws/ angel
---	---

Figure 11. Rectangular vertical duct, insulation CONLIT Fire Mat EI30, fire resistance class EI 30

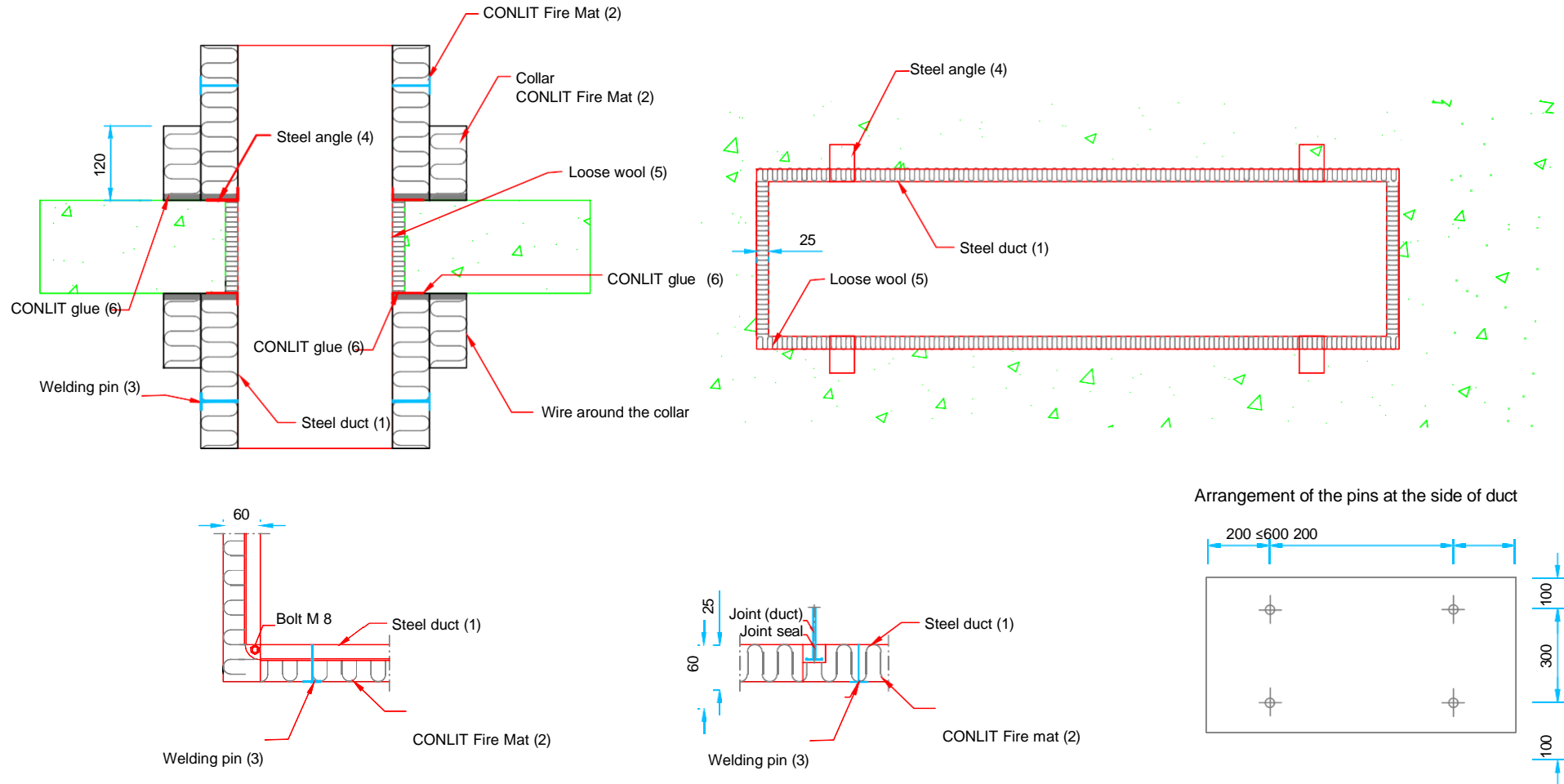

1	Steel duct Lindab LKR with Lindab RJFP 20 mm flanges, The corners of flanges were joined with M8 bolts; The ducts were sealed with an EPDM seal 5 x15 mm or similar.
2	CONLIT Fire Mat EI30 thickness 60 mm, density 70 kg/m ³ faced with steel mesh sewn to the wool with stainless steel wires, between wool and mesh a black aluminum foil is placed. End of collar surface is covered with the black Alu-foil
3	Welding pins Ø3 mm with preset washers, length 60 mm Ø30 mm
4	Steel angel 40 x 60 x 40 x 3 mm 4 pcs. at both sides of the deck fixed to the duct with two 3.2 x 25 mm screws/angel
5	Loose wool stopping i.e. CONLIT Fire Mat
6	CONLIT glue

Figure 12 (1/2). Rectangular horizontal duct, insulation CONLIT Fire Board EI30, fire resistance class EI 30

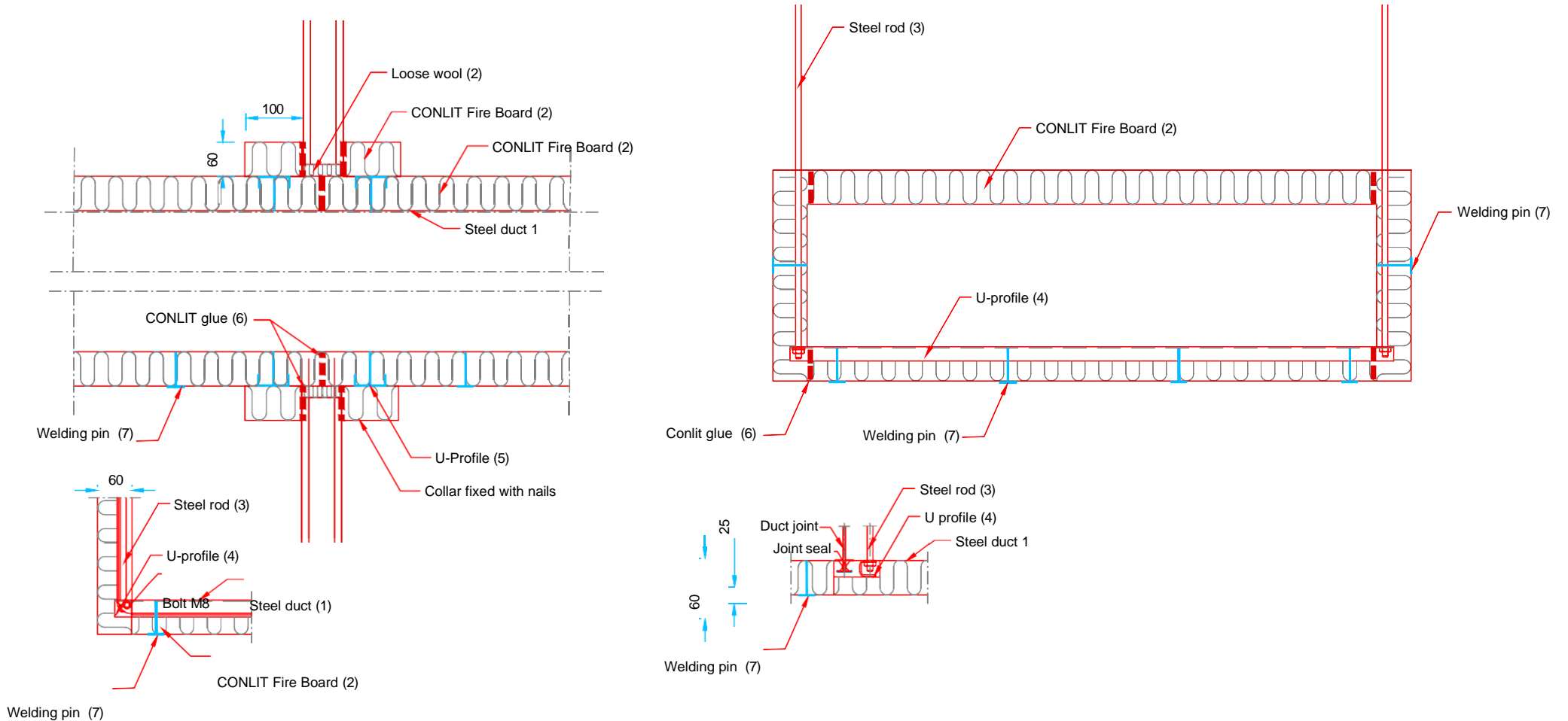

1	Steel duct Lindab LKR with Lindab RJFP 20 mm flanges, The corners of flanges were joined with M8 bolts; The ducts were sealed with an EPDM seal 5 x15 mm or similar.
2	CONLIT Fire Board EI30: thickness 60 mm, density 100 kg/m ³ faced with a black alu-foil. All joints and edge surfaces covered with alu foil tape
3	Steel rod dimensions, see requirements in table 6
4	U-profile Hilti MM-C-30; 30 x 30 x30 x 1 mm or similar.
5	U-profile 60 x 25 x25 x 1,6 mm; approx. 20 mm from the wall at each side fixed to the duct with 100 mm self tapping screws max 300 mm c/c at least 2 screws per profile
6	CONLIT glue

7	Welding pins Ø3 mm with preset washers, length 60 mm Ø30 mm
---	---

Figure 12 (2/2). Rectangular horizontal duct, insulation CONLIT Fire Board EI30, fire resistance class EI 30: arrangement of steel pins

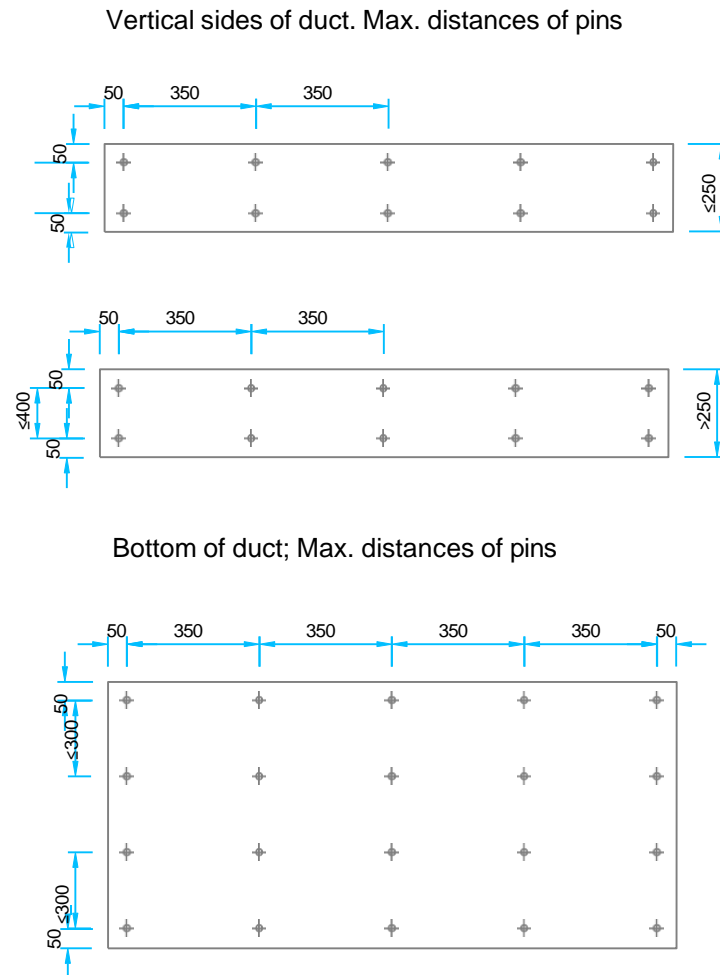
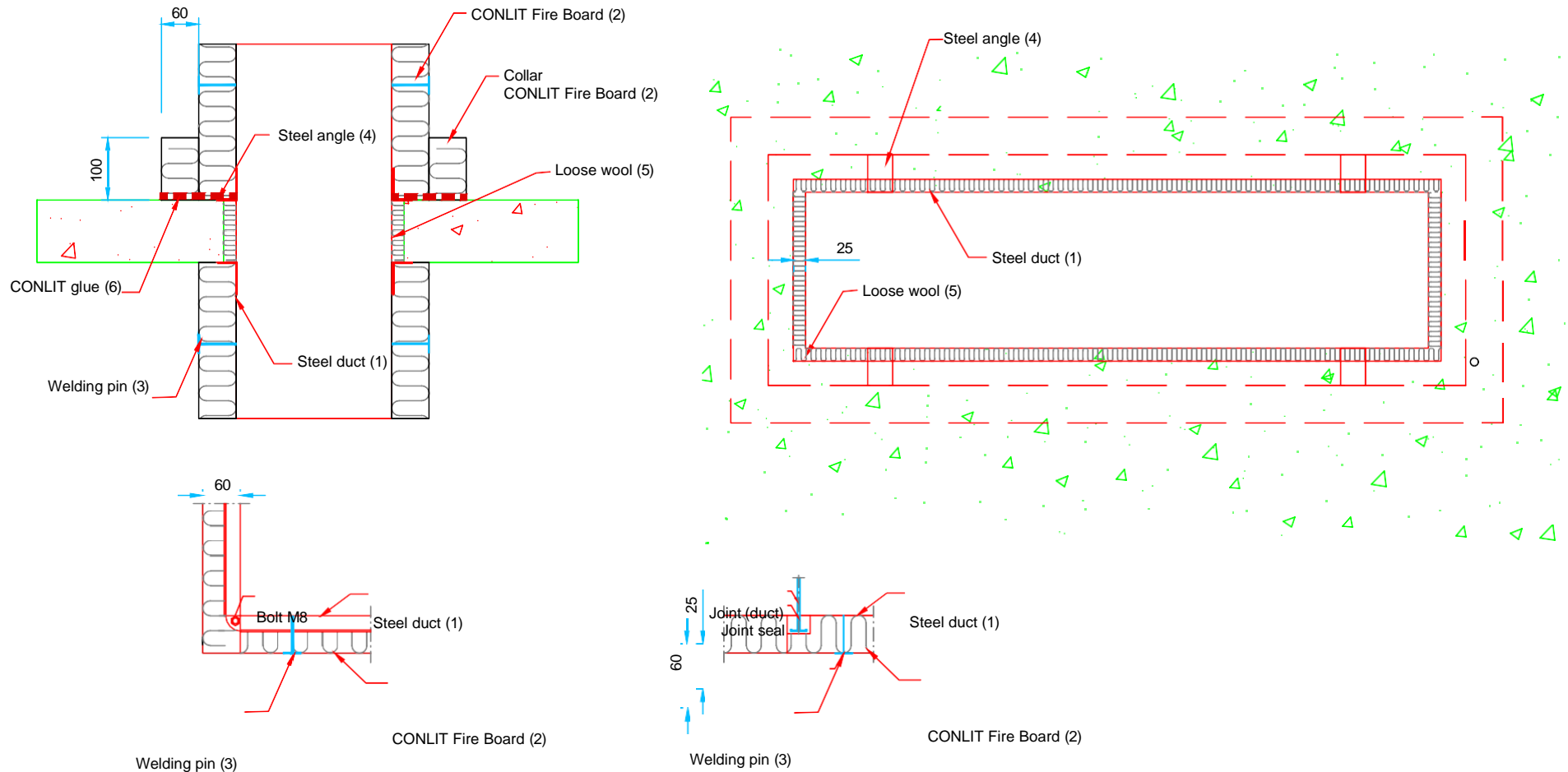

Figure 13 (1/2). Rectangular vertical duct, insulation CONLIT Fire Board EI30, fire resistance class EI 30



1	Steel duct Lindab LKR with Lindab RJFP 20 mm flanges, The corners of flanges were joined with M8 bolts; The ducts were sealed with an EPDM seal 5 x15 mm or similar
2	CONLIT Fire Board EI30: thickness 60 mm, density 100 kg/m ³ faced with a black alu-foil. All joints and edge surfaces covered with alu-z e foil tape
3	Welding pins Ø3 mm with preset washers, length 60 mm Ø30 mm
4	Steel angel 40 x 60 x 40 x 3mm 4 pcs. at both sides of the deck fixed to the duct with two 3.2 x 25 mm screws/angel
5	Loose wool stopping i.e. CONLIT Fire Board EI30

6	CONLIT glue
---	-------------

Figure 13 (2/2). Rectangular vertical duct, insulation CONLIT Fire Board EI30, fire resistance class EI 30: arrangement of steel pins

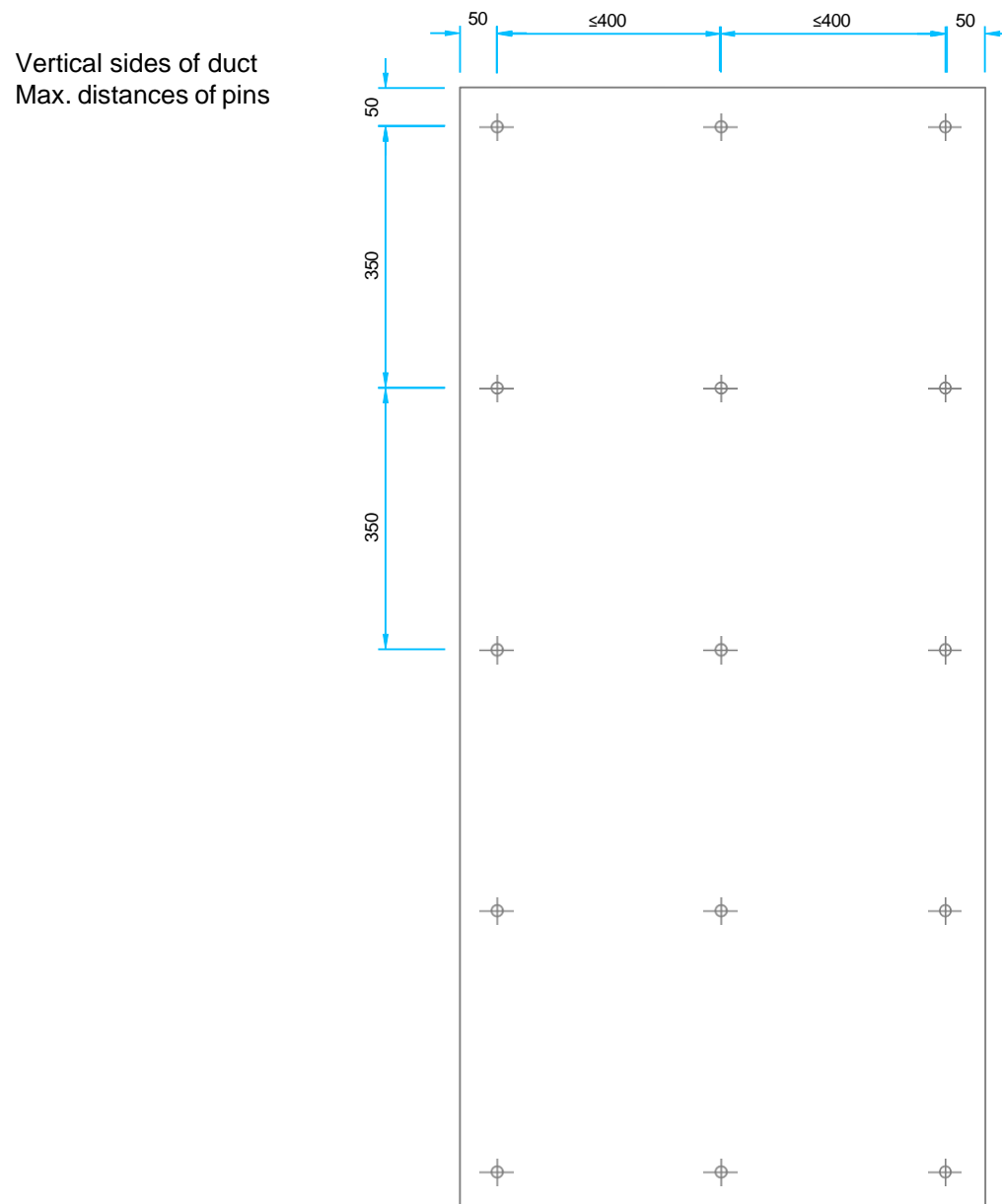
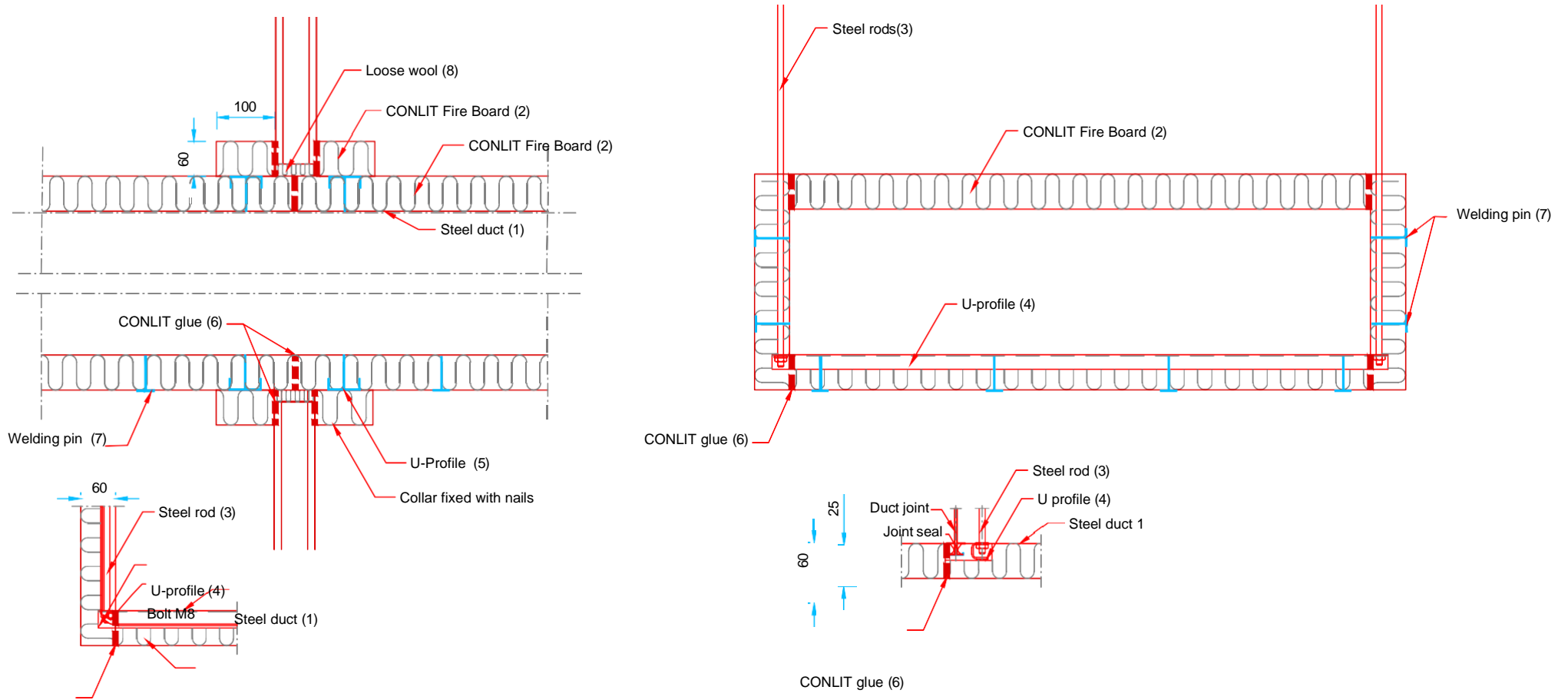

Figure 14 (1/2). Rectangular horizontal duct, insulation CONLIT Fire Board EI60, fire resistance class EI 60



CONLIT Fire Board (2)

CONLIT glue (6)

1	Steel duct Lindab LKR with Lindab RJFP 20 mm flanges, The corners of flanges were joined with M8 bolts; The ducts were sealed with an EPDM seal 5 x15 mm or similar.
2	CONLIT Fire Board EI60: thickness 60 mm, density 160 kg/m ³ faced with a black alu-foil. All joints and edge surfaces covered with alu foil tape
3	Steel rod dimensions, see requirements in table 6
4	U-profile Hilti MM-C-30; 30 x 30 x 1 mm or similar
5	U-profile 60 x 25 x25 x 1,6 mm; approx. 20 mm from the wall at each side fixed to the duct with 100 mm self tapping screws max 300 mm c/c at least 2 screws per profile
6	CONLIT glue
7	Welding pins Ø3 mm with preset washers, length 60 mm Ø30 mm
Date of issue December 7, 2017	ROCKWOOL FLEXIBATTS or similar density stone wool (30 kg/m ³) Date of update December 1, 2023

Figure 14 (2/2). Rectangular horizontal duct, insulation CONLIT Fire Board EI60, fire resistance class EI 60: arrangement of steel pins

Vertical sides of duct. Max. distances of pins

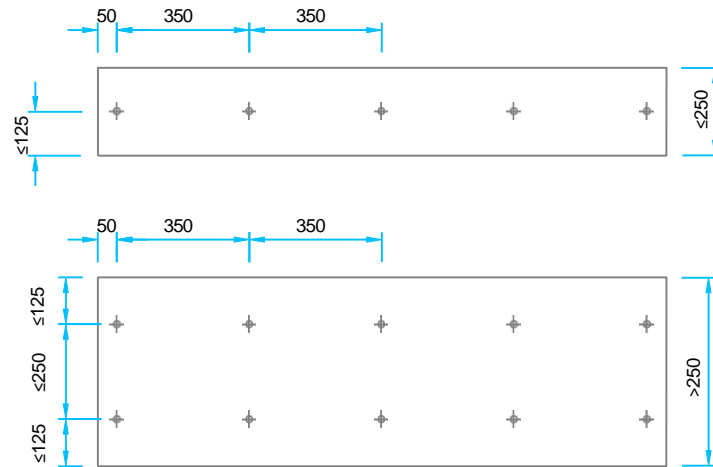

Bottom of duct. Max. distances of pins

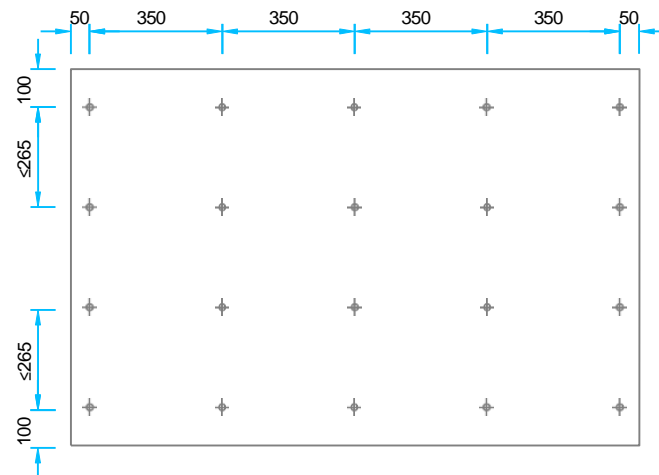
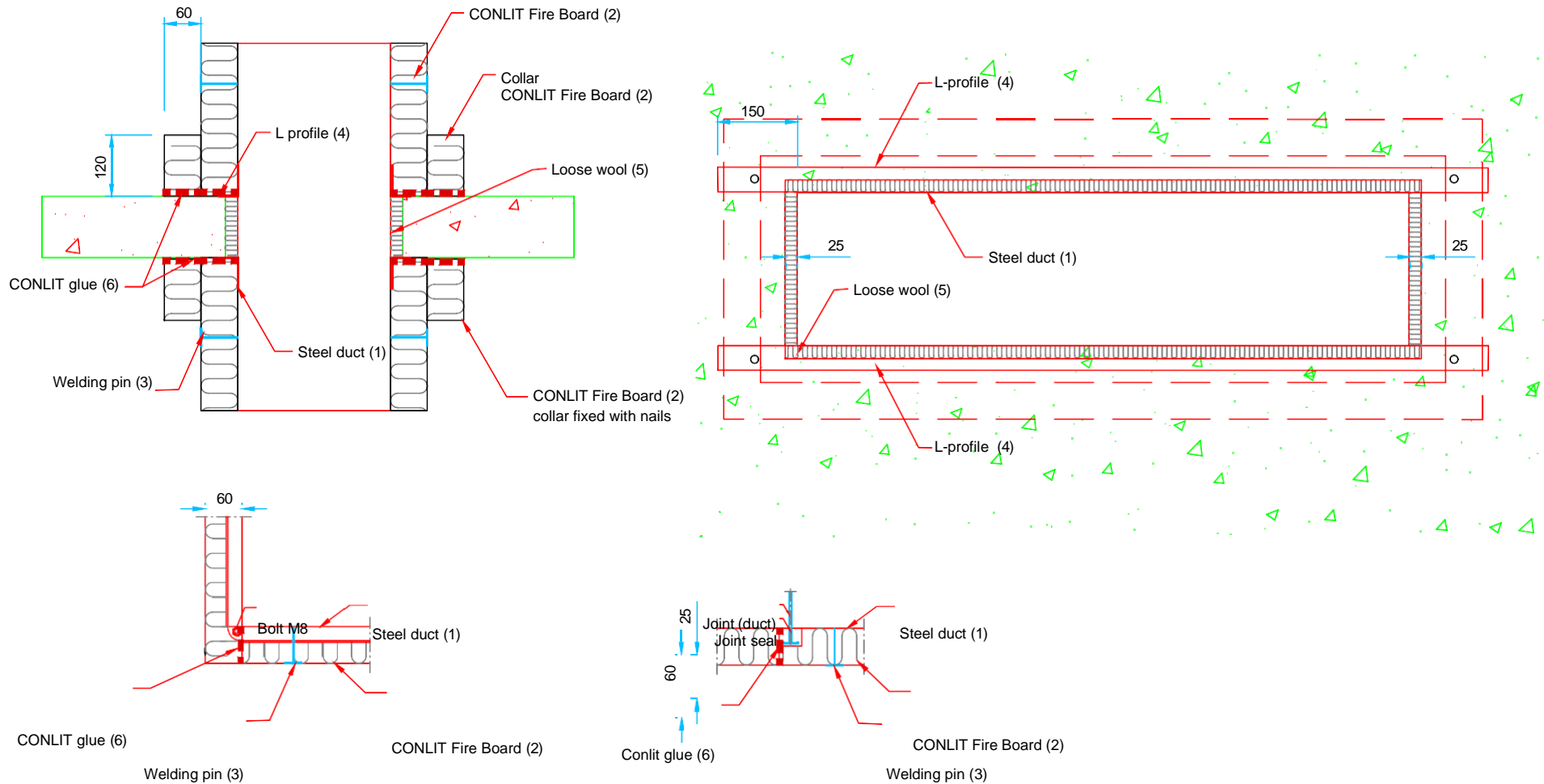

Figure 15 (1/2). Rectangular vertical duct, insulation CONLIT Fire Board EI60, fire resistance class EI 60



1	Steel duct Lindab LKR with Lindab RJFP 20 mm flanges, The corners of flanges were joined with M8 bolts; The ducts were sealed with an EPDM seal 5 x 15 mm or similar.
2	CONLIT Fire Board EI60: thickness 60 mm, density 160 kg/m ³ faced with a black alu-foil. All joints and edge surfaces covered with alu foil tape
3	Welding pins Ø3 mm with preset washers, length 60 mm Ø30 mm
4	Steel profile L 40 x 40 x 3 mm; L = (width of duct + 300) mm fixed to the duct with 3.2 x 25 mm screws CC 200 mm, and to the deck with 7.5 x 62 mm screws

Figure 15 (1/2). Rectangular vertical duct, insulation CONLIT Fire Board EI60, fire resistance class EI 60

5	ROCKWOOL FLEXIBATTS or similar density stone wool (minimum 30 kg/m ³).
6	CONLIT glue

Figure 15 (2/2). Rectangular vertical duct, insulation CONLIT Fire Board EI60, fire resistance class

: arrangement of steel pins

Vertical sides of duct
Max. distances of pins

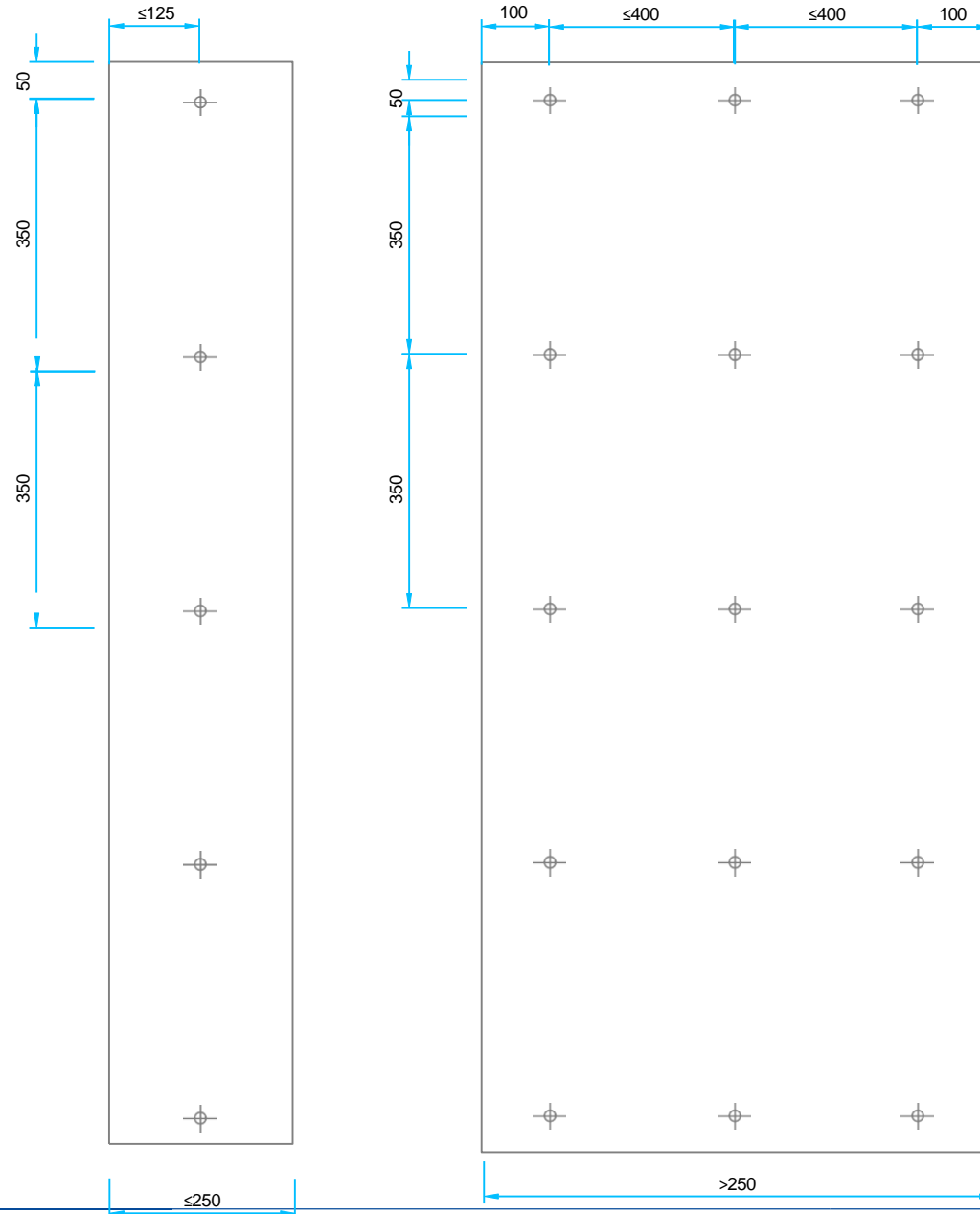
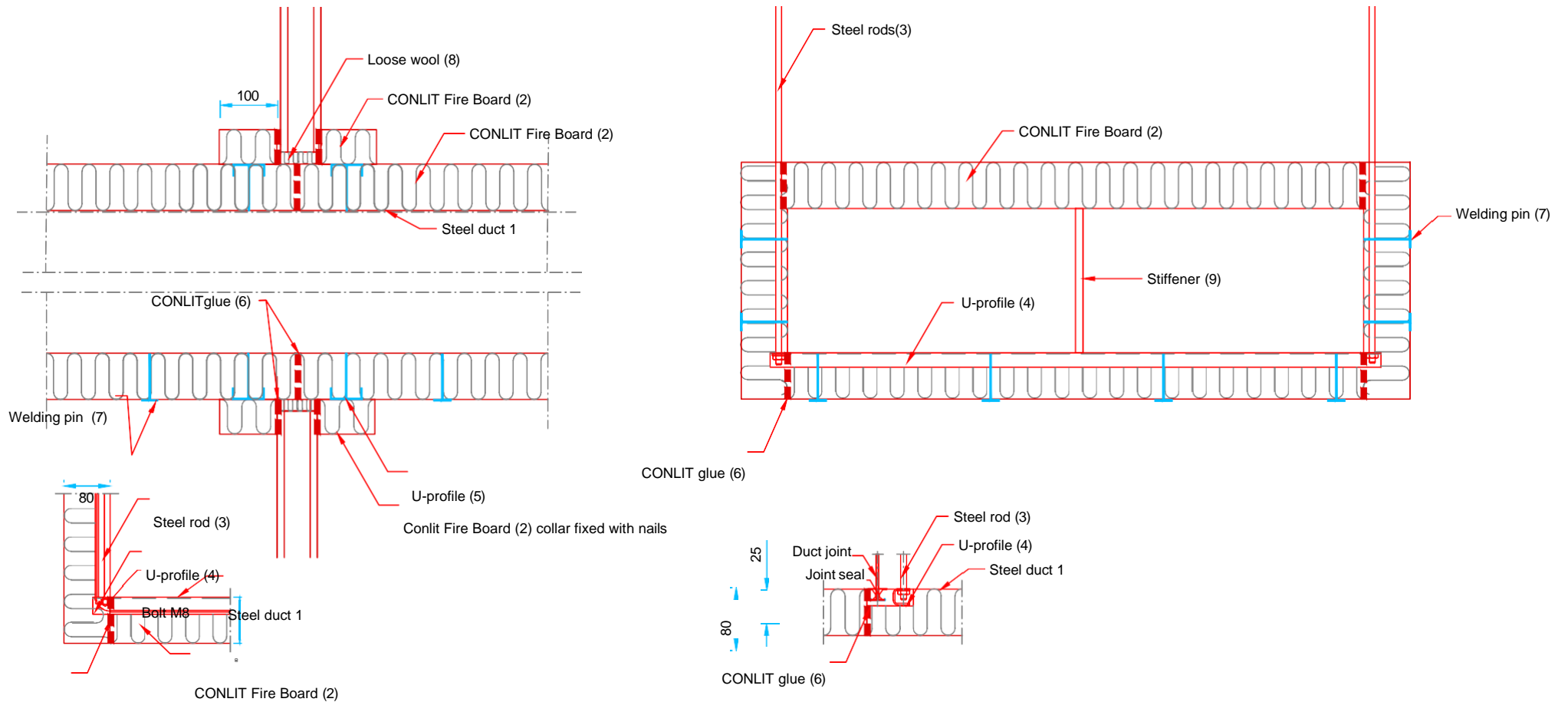

Figure 16 (1/2). Rectangular horizontal duct, insulation CONLIT Fire Board EI90, fire resistance class EI 90



CONLIT glue (6)

CONLIT Fire Board (2)

1	Steel duct Lindab LKR with Lindab RJFP 20 mm flanges, The corners of flanges were joined with M8 bolts; The ducts were sealed with an EPDM seal 5 x15 mm or similar.
2	CONLIT Fire Board EI90: thickness 80 mm, density 180 kg/m ³ faced with a black alu-foil. All joints and edge surfaces covered with alu foil tape
3	Steel rods M10
4	Steel rod dimension see table 6
5	U-profile 60 x 25 x 25 x 1,6 mm; approx. 20 mm from the wall at each side fixed to the duct with 100 mm self tapping screws max 300 mm c/c at least 2 screws per profile
6	CONLIT glue
7	Welding pins Ø3 mm with preset washers, length 83 mm, Ø30 mm
8	Loose wool ROCKWOOL FLEXIBATTS or same density stone wool (30 kg/m ³).
9	Pipe stiffener Ø15 mm, one/duct segment

Figure 16 (2/2). Rectangular horizontal duct, insulation CONLIT Fire Board EI90, fire resistance class EI 90: arrangement of steel pins

Vertical sides of duct. Max. distances of pins

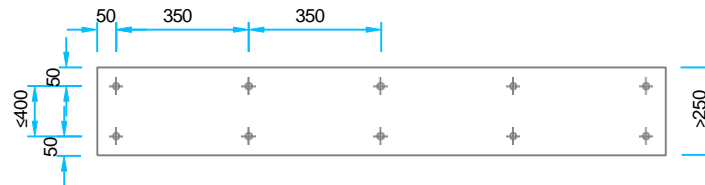
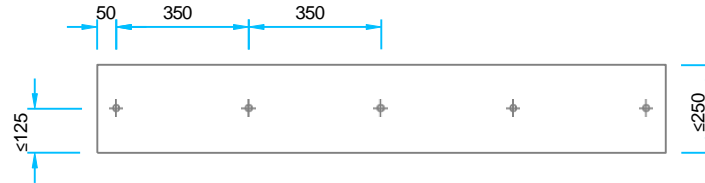

Bottom of duct; Max. distances of pins

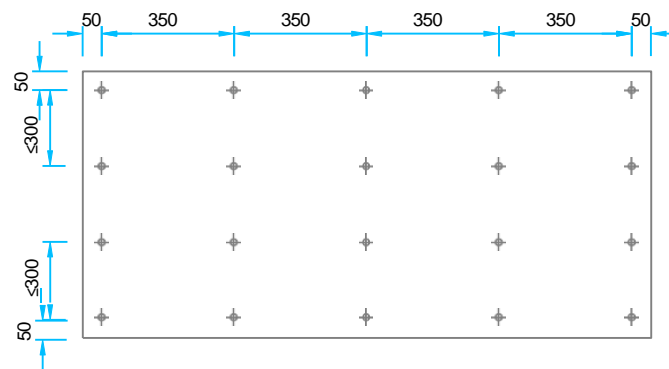
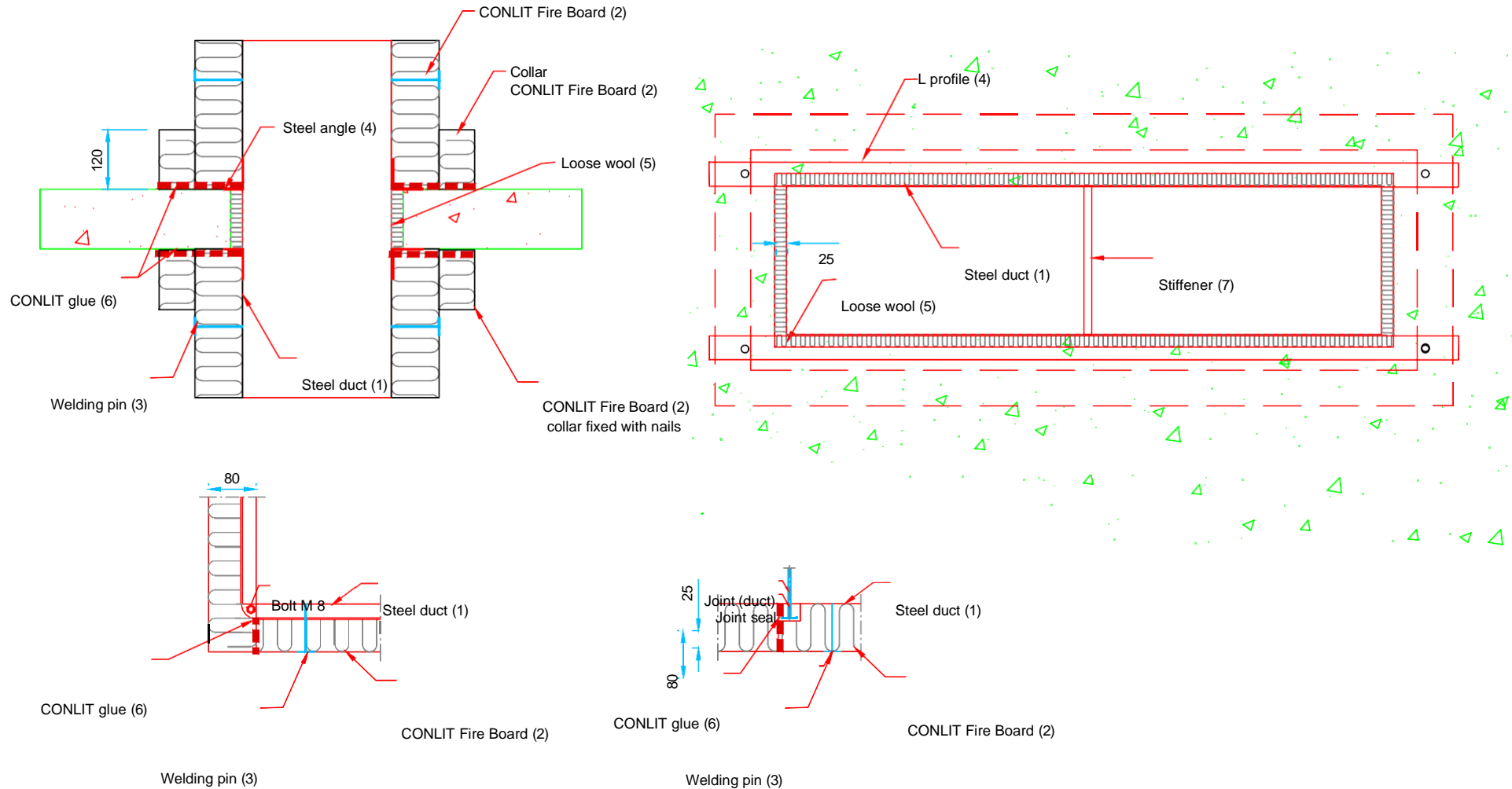

Figure 17 (1/2). Rectangular vertical duct, insulation CONLIT Fire Board EI90, fire resistance class EI 90



1	Steel duct Lindab LKR with Lindab RJFP 20 mm flanges, The corners of flanges were joined with M8 bolts; The ducts were sealed with an EPDM seal 5 x15 mm
2	CONLIT Fire Board EI90: thickness 80 mm, density 180 kg/m ³ faced with a black alu-foil. All joints and edge surfaces covered with alu foil tape
3	Welding pins Ø3 mm with preset washers, length 83 mm, Ø30 mm
4	Steel profile L 50 x 50 x 3mm; L = (width of duct + 300)mm fixed to the duct with 3.2 x 25 mm screws CC 200, and to the deck with 7.5 x 62 mm screws
5	ROCKWOOL FLEXIBATTS or same density stone wool (at least 30 kg/m ³).

6	CONLIT glue
7	Pipe stiffener Ø15, mm one/duct segment

Figure 17 (2/2). Rectangular vertical duct, insulation CONLIT Fire Board EI90, fire resistance class EI 90: arrangement of steel pins

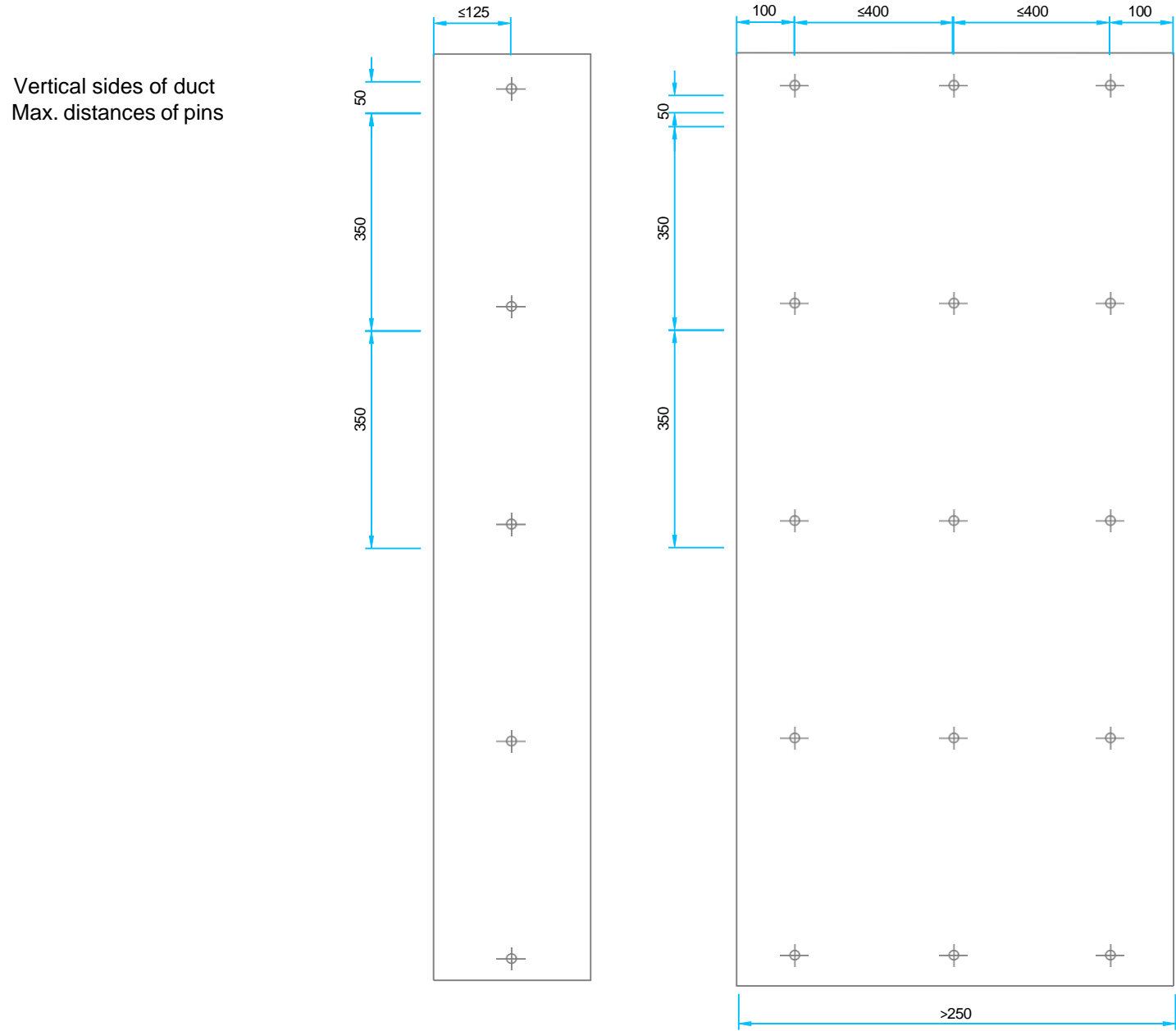

≤250

9	ROCKWOOL FLEXIBATTS or similar stone wool (density at least 30 kg/m ³).
---	---

Figure 18 (2/2). Rectangular horizontal duct, insulation CONLIT Fire Board EI120, fire resistance class 120: arrangement of steel pins

Vertical sides of duct. Max. distances of pins

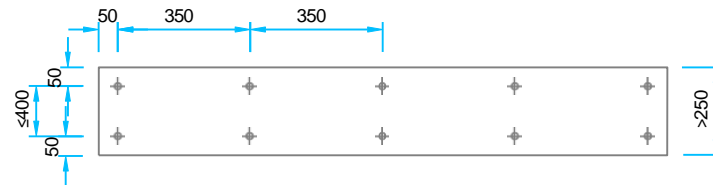
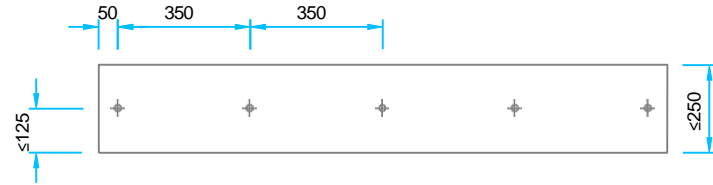

Bottom of duct; Max. distances of pins

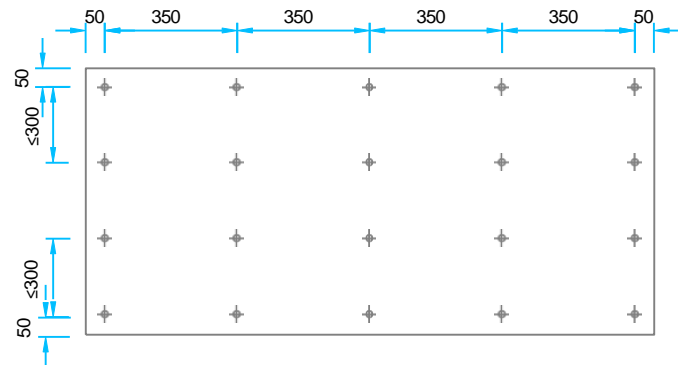
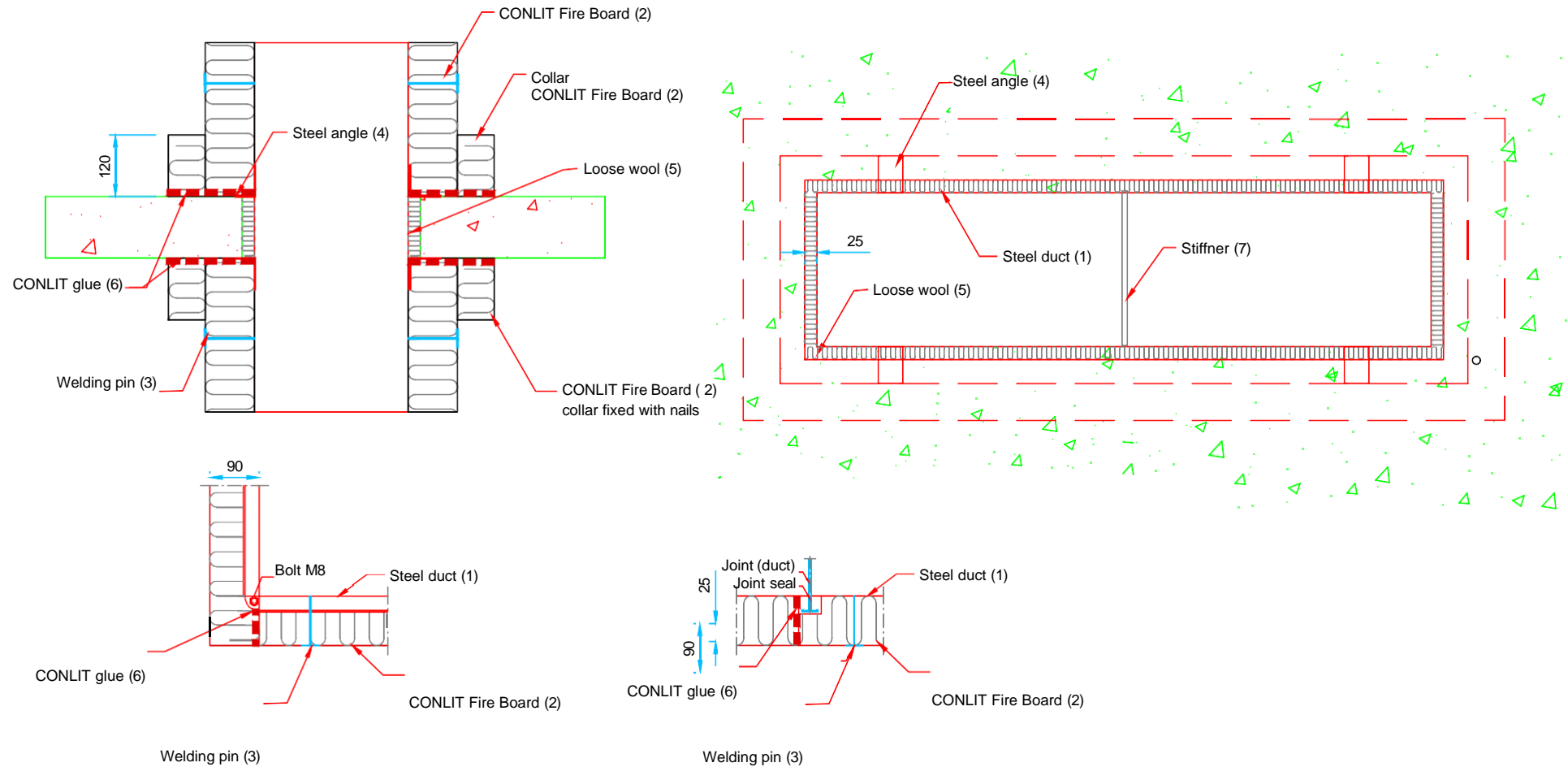

Figure 19 (1/2). Rectangular vertical duct, insulation CONLIT Fire Board EI120, fire resistance class EI 120



1	Steel duct Lindab LKR with Lindab RJFP 20 mm flanges, The corners of flanges were joined with M8 bolts; The ducts were sealed with an EPDM seal 5 x15 mm or similar.
2	CONLIT Fire Board EI120: thickness 90 mm, density 180 kg/m ³ faced with a black alu-foil. All joints and edge surfaces covered with coroplast tape
3	Welding pins Ø3 mm with preset washers, length 90 mm Ø30 mm
4	Steel angel 50 x 50 x 45 x 2,5mm; 4 pcs. at both sides of the deck fixed to the duct with two 3.2 x 25 mm screws/angel
5	ROCKWOOL FLEXIBATTS or similar stone wool (minimum density 30 kg/m ³).
6	CONLIT glue

7	Pipe stiffner Ø 15 mm; one per duct segment
---	---

Figure 19 (2/2). Rectangular vertical duct, insulation CONLIT Fire Board EI120, fire resistance class EI 120

Vertical sides of duct.
Max. distances of pins

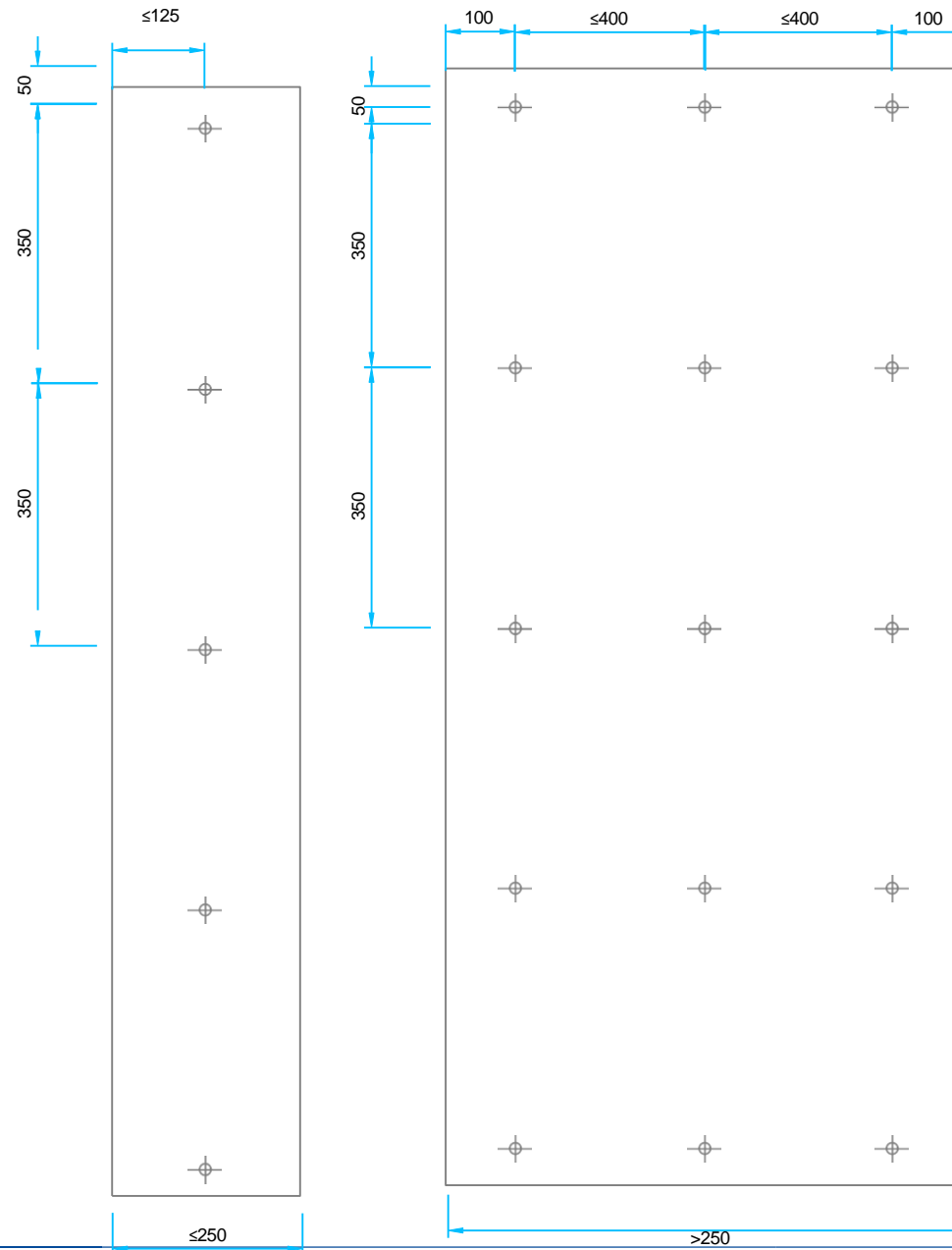
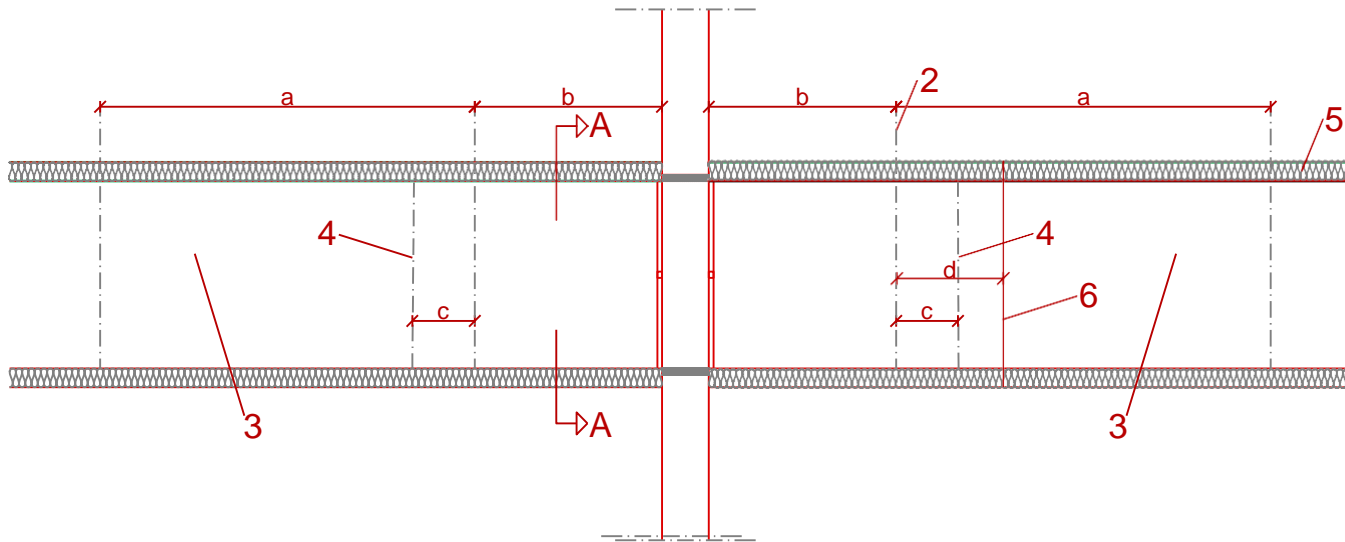

Figure 20. Rectangular duct, maximum distances between suspension devices and maximum distance of suspension devices from the duct joint, joint insulation and from the separating construction



	CONLIT Fire Mat EI30	CONLIT Fire Board EI30	CONLIT Fire Board EI60	CONLIT Fire Board EI90	CONLIT Fire Board EI120
a Max distance between suspension hangers	1500 mm	1500 mm	1500 mm	1500 mm	1500 mm
b Max distance from wall to hanger	500 + 100 mm	300 + 100 mm	350 + 100 mm	350 + 100 mm	310 + 100 mm
c Max distance from hanger to joint in duct	10 + 100 mm	50 + 100 mm	75 + 100 mm	10 + 100 mm	10 + 100 mm
d Max distance from hanger to joint in insulation	100 + 100 mm	350 + 100 mm	80 + 100 mm	80 + 100 mm	270 + 100 mm

1	Penetration	See A-A
2	Drop rod	Steel rod dimensions, requirements in table 6
3	Duct	Lindab LKR
4	Joint in duct	
5	Fire protection	CONLIT Fire Mat or CONLIT Fire Board
6	Joint in insulation	

Figure 21. Duct support in openings larger than tested, filled with Conlit Coated Batt. Fire resistance class EI 30.

Horizontal duct is supported with L-profiles on both sides of the penetration
 Vertical duct is supported with L-profiles on the upper side of the penetration

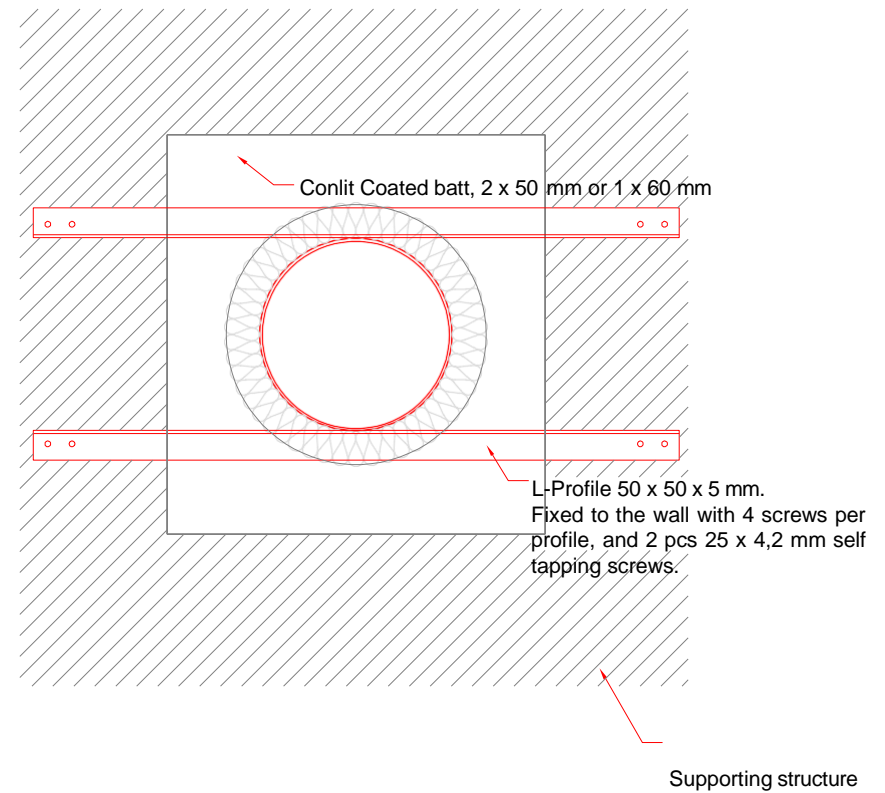
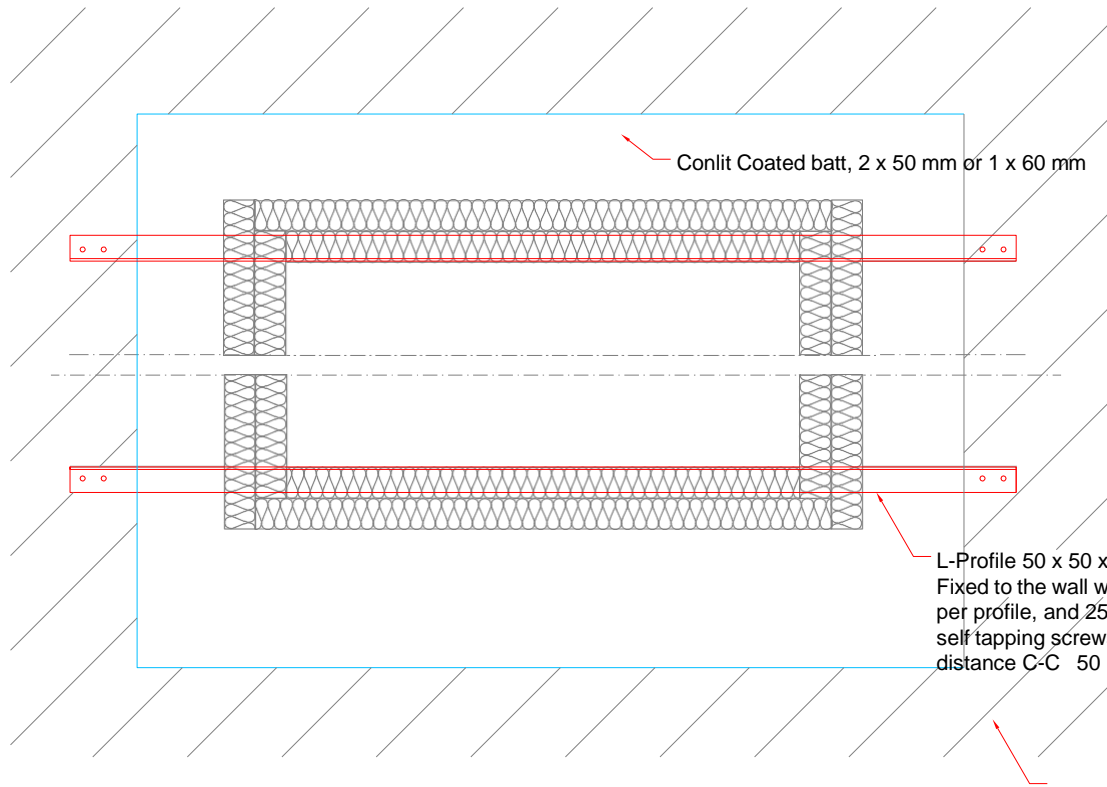

Figure 22. Sealing opening, larger than tested with, Conlit Coated batt insulation board. Fire resistance class EI 30. Horizontal ducts. Sealing penetration, see Annex A2 Figures 1 and 10

In flexible walls, before installing Conlit Coated Batt insulation, gypsum boards shall be installed on all four sides of the opening. With gypsum boards at least the same fire resistance class with the separating wall shall be reached.

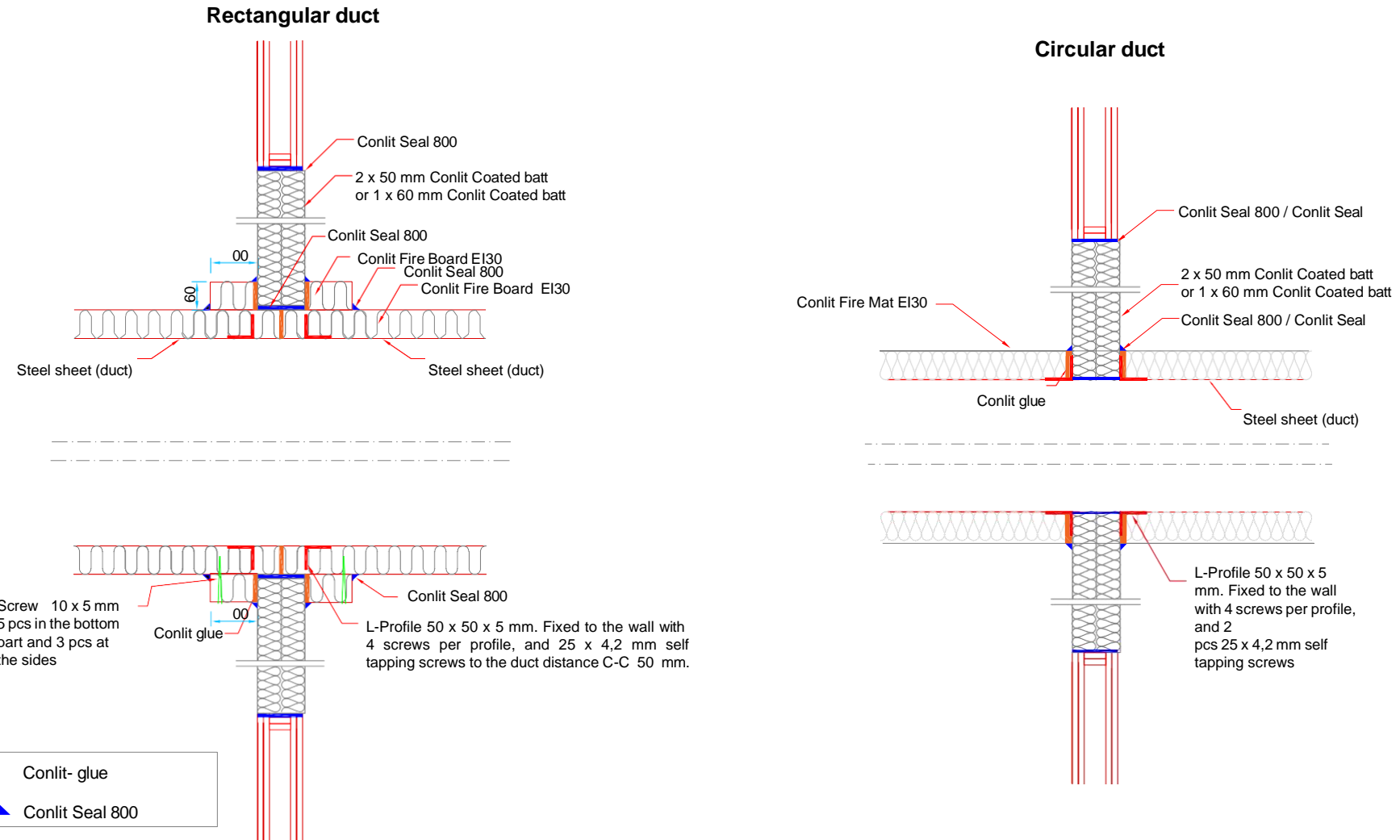

Figure 23. Sealing opening, large than tested, with Conlit Coated batt insulation board. Fire resistance class EI 30. Vertical ducts. Sealing penetration, see Annex A2 Figures 2 and 11

