

FIREPRO® DuctRock Slab

Tools required

- Sharp insulation knife or insulation saw
- Tape measure
- Welded pins & washers
- Scissors

Ancillary products

Self adhesive black aluminium foil tape, FIREPRO® Glue, RWA45, 1.5mm thick steel u-profile (60 x 25 mm), nails

Fixing and application

Fire Performance

FIREPRO® DuctRock® Slab can be rapidly installed onto rectangular and square steel ductwork using a combination of Ø2.7 - Ø3.0mm stud welded pins, Ø30mm steel washers and ROCKWOOL FIREPRO® Glue. All board abutments and cross joints must be covered with ROCKWOOL black aluminium foil tape.

DuctRock Slab thickness (mm)	Stud welded pin length (mm)
60	62mm
80	82mm
90	92mm

FIREPRO® DuctRock® is easily cut with a hand saw or alternatively a circular/table saw. The top and bottom slabs should be cut 10mm wider than the width of the duct to ensure a tight cross joint with the side slabs. The side slabs should be cut to the height of the duct (H) + 2 x the insulation thickness as shown in Figure 1.

Top slab

When installed within horizontal applications the top boards do not require any stud welded pins and is simply positioned onto the duct with all board joints bonded with FIREPRO® Glue. Board joints must be covered using ROCKWOOL black foil tape.

Figure 1

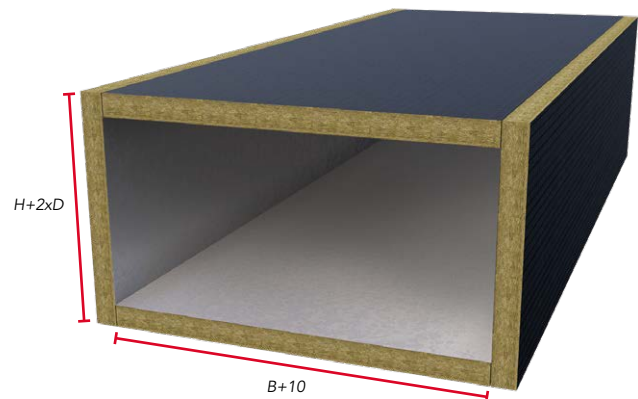

Figure 2

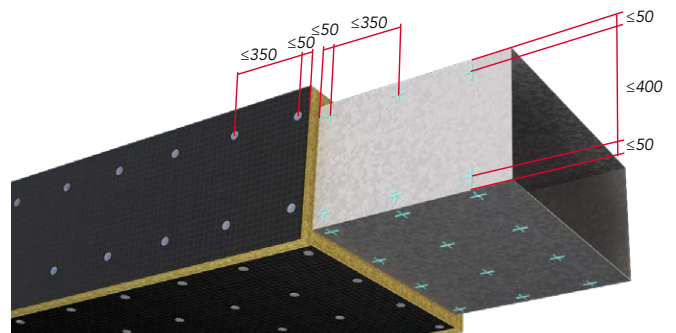
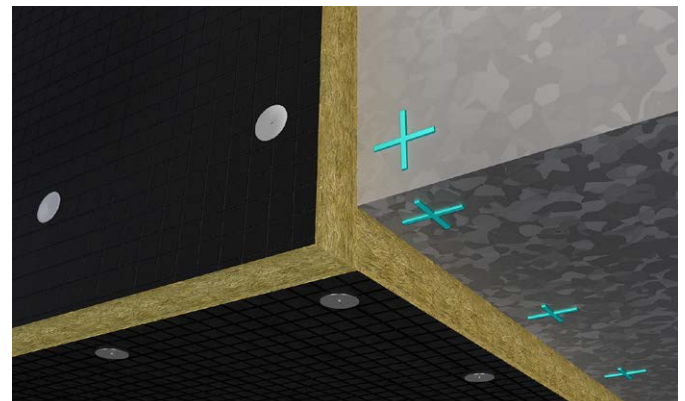

Figure 3

Cross joint horizontal duct



Side wall slabs

The side wall slabs are installed using stud welded pins with 350mm maximum centres along the length of the duct and 400mm centres across the depth as shown in Figure 2.

Side wall slabs must overlap the top and bottom boards as shown in Figures 3 & 4. All cross joints must be bonded with ROCKWOOL FIREPRO® Glue.

Note: To ensure that there is a strong bond between the welded pin and the duct, always ensure that the welded pin is sufficiently isolated from the foil surface of the insulation during welding.

Base slab

Install the base slabs with stud welded pins at a maximum of 350mm centres along the length of the duct and 300mm centres across the width of horizontal ducts and 450mm across the width of vertical ducts as shown as shown in Figures 5 and 6.

Detailing around flanges and drop rod hangers

Where the DuctRock® Slab bypasses a flange, drop rod hanger or both, cut a notch into the insulation as shown in Figure 7a-c. The insulation can easily be cut with a sharp knife or hand saw. All board joints must be bonded with FIREPRO® Glue.

Dry wall penetration

In order to maintain fire performance, provide stability and minimise noise transfer, ROCKWOOL have developed a patented solution for installing DuctRock® Slab at the point where the duct penetrates a dry wall system.

Figure 4
Cross joint vertical duct

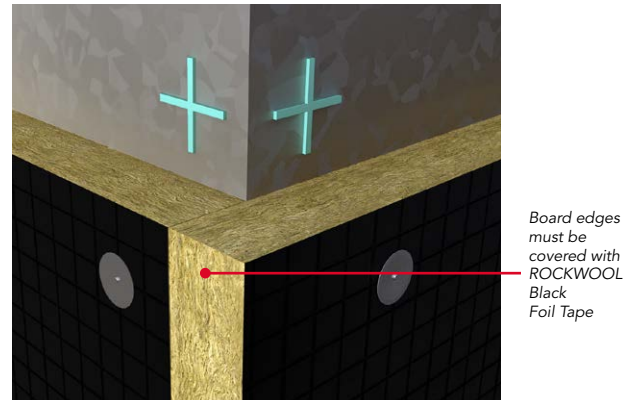

Figure 5
Horizontal duct

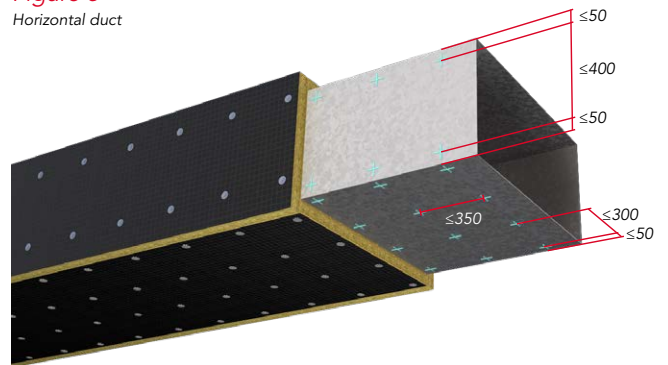
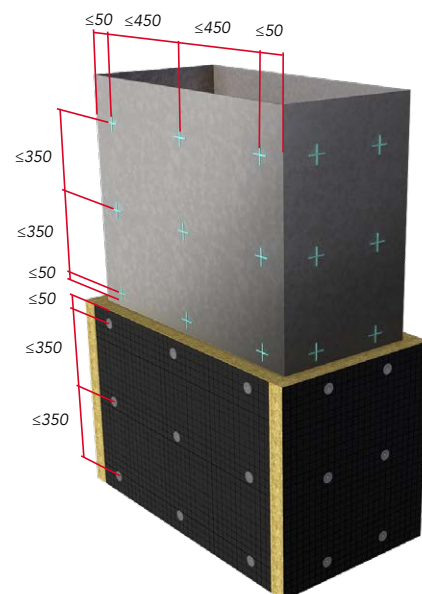

Figure 6
Vertical duct



Installation Procedure: Dry wall Penetration

1. A joint in the DuctRock® Slab must be accommodated at the centre point of the aperture, as shown in Figure 10.
2. Fill the remaining annular space between the DuctRock® Slab and supporting structure of the dry wall system with ROCKWOOL RWA45 as shown in Figure 9.
3. To stiffen the duct around the penetration a 1.5mm thick steel u-profile (60 x 25 mm) must be fitted approx. 20mm from the wall, to both the vertical and horizontal sides of the duct (both sides of the aperture) the length of the profile can be determined using the following formula:

$$\text{Duct Width/Height} + (2 \times \text{Insulation Thickness}) - 50\text{mm}$$

Examples shown in table below:

Duct size (mm)	Insulation thickness (mm)	U-Profile length (mm)	
		Horizontal	Vertical
1500 (L) x 1000 (W) x 500 (H)	90	1130	630
1500 (L) x 1000 (W) x 250 (H)	90	1130	380

4. Before applying the u-profile to the DuctRock® Slab slits must be cut into the insulation to allow the profile sides to penetrate the insulation (Figure 10). The u-profile can be attached to the ductwork using 100mm self-tapping screws. 4No to the top and bottom slabs and 2No to the vertical slabs.
5. Once the u-profiles have been applied an insulated collar must be installed around the perimeter of the aperture. The collar can be simply cut from the DuctRock® Slab. Fix the collars in place with FIREPRO® Glue as shown in Figure 9. Use nails to temporarily hold the collars in place whilst the glue cures.
6. ROCKWOOL Black foil tape can be used to cover any exposed edges of the collars.

Figure 7a

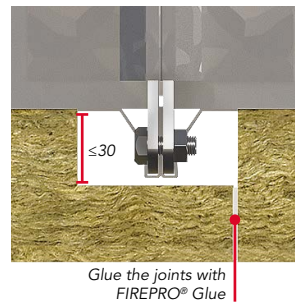
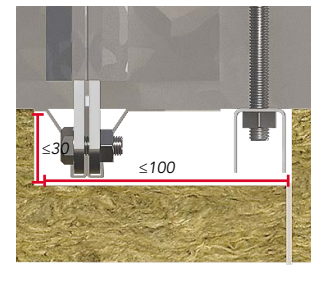

Figure 7b



Glue the joints with FIREPRO® Glue

Figure 7c

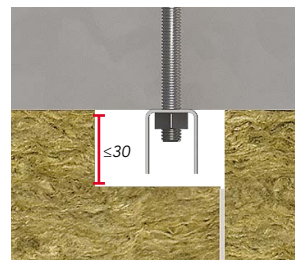

Figure 8

ROCKWOOL Patented Dry Wall Penetration Detail

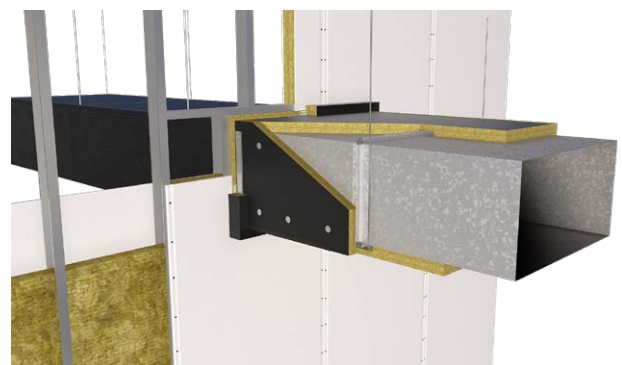
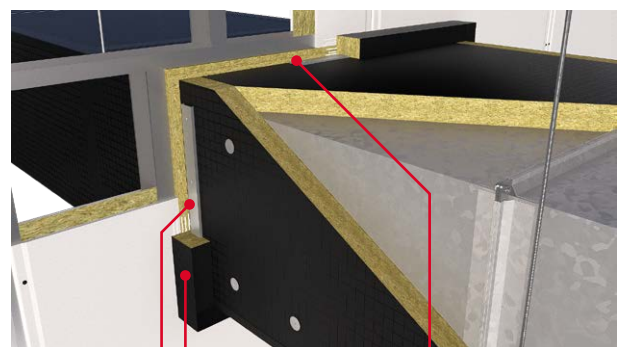

Figure 9



Steel u-profile fixed 20mm from the wall

60mm x 100mm DuctRock collars bonded to the substrate with FIREPRO® Glue

Annular space filled with ROCKWOOL RWA45

Installation Procedure: Floor Penetration

1. Maintain a 30mm gap between the ductwork and floor structure. Fill the gap between the duct and the floor structure with a ROCKWOOL Slab e.g. ROCKWOOL RWA45 as shown in Figure 11a. The flexible slab can be sealed within the void using FIREPRO® Glue.
2. Secure the duct to the floor structure using 4 no. 50 x 50 x 45 x 2.5mm galvanised steel angles to both sides of the aperture. The angles can be fixed using 2No 3.2 x 25mm self-tapping screws. Alternatively, the duct can be secured with a 40 x 40 x 3mm L profile as shown in Figure 11b. The length of the L profile should be equal to the width of the duct and installed to both sides (duct width).
3. Apply a DuctRock® collar to the perimeter of the aperture and on both sides as shown in Figure 11a. The collars can be fixed using FIREPRO® Glue and temporarily held in place with nails until the glue cures.

Figure 10

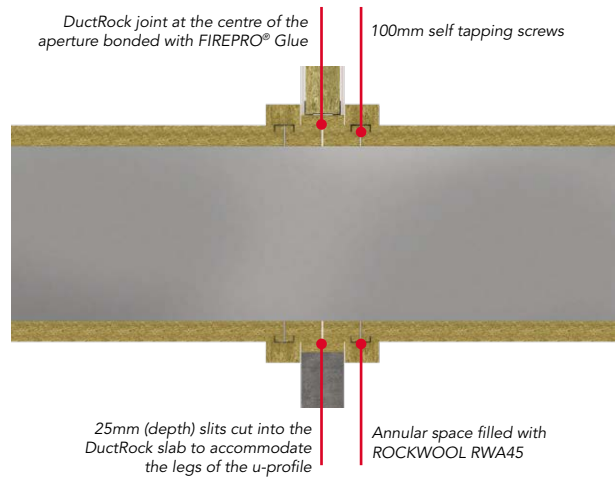

Figure 11a

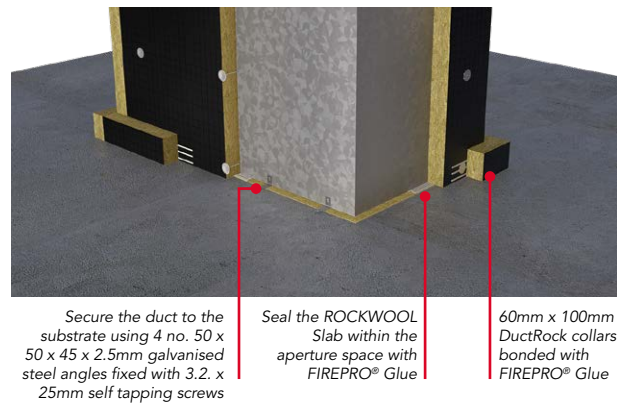
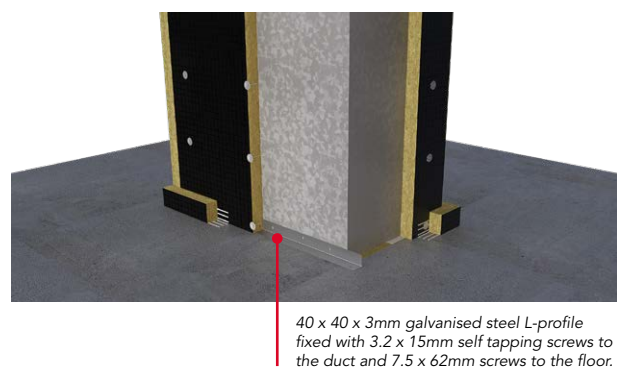

Figure 11b



Elbows

Elbows can be protected by cutting the DuctRock® Slab into fan shaped segments as shown in Figure 12a. Alternatively v-shaped slits can be cut into the back of the DuctRock Slab allowing it to wrap around the elbow as shown in Figure 12b. Fill the v-shaped channels with FIREPRO® Glue before applying to the duct and use nails to temporarily hold the insulation in place whilst the glue cures.

Access hatches

DuctRock® Slab can be cut and positioned within a steel frame to form a removable cover in the location of the steel access hatch. The insulated cover can be attached to the duct using 4N° M8 threaded rods (Figure 13a) ensuring the rods are secured on both sides of the duct. The cover is then fixed to the rods using steel M8 nuts and washers. The thickness of insulation should be appropriate to the fire resistance required.

Ancillaries

- FIREPRO Glue and ROCKWOOL Black Foil Tape is available from ROCKWOOL Stockists
- Stud welded pins and self-tapping screws are available through CEVaC Limited, Tel: +44 (0)1403 786503



Figure 12a

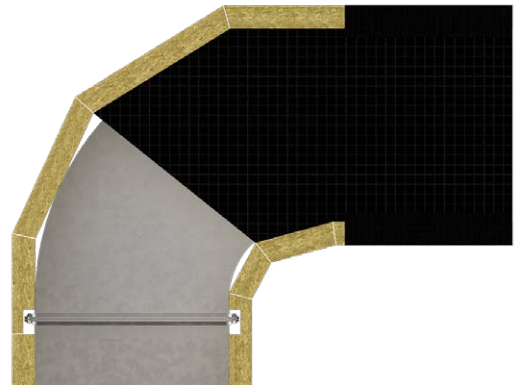

Figure 12b

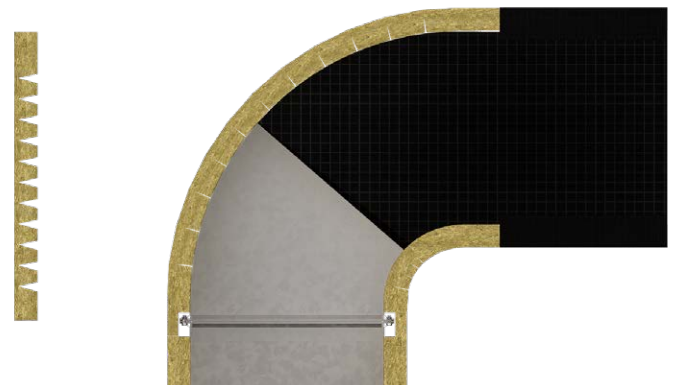

Figure 13a

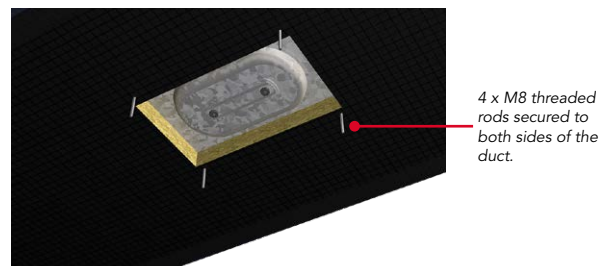
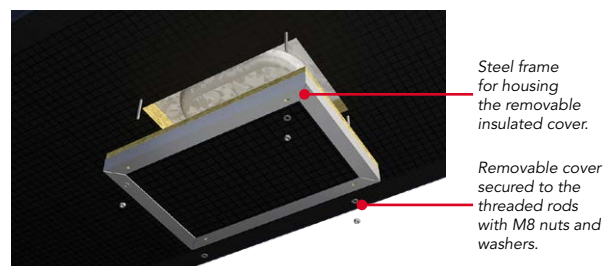

Figure 13b



Health & safety

The mechanical effect of fibres in contact with skin may cause temporary itching.



*Cover exposed skin
When working in
unventilated area wear
disposable face mask.*



*Clean area using vacuum
equipment.*



*Waste should be disposed of
according to local regulations.*



*Rinse in cold water before
washing.*



*Ventilate working area if
possible.*



*Wear goggles when working
overhead.*